



Version 1.3 (Rev 1)

**Indoor CO2, Temperature and Humidity  
Monitor**

Thank you for your purchase of the CO2-TH CO2, Temperature and Humidity Monitor. This device has been designed, built, and tested to be an exceptionally reliable product. Great effort has been taken to ensure ease of use and reliable monitoring of Carbon Dioxide, temperature, and humidity within an interior space.

Take time to read this manual carefully to understand how the product can be used and applied for your specific application.

*Great care has been taken in the preparation of this manual. However, iO HVAC Controls takes no responsibility for errors or omissions contained in this document. It is the responsibility of the installer to ensure that this product and any equipment connected to it operates in a safe and efficient manner.*

*Due to ongoing product improvement iO HVAC Controls reserves the right to change the specifications of this product (or its components) without notice.  
All rights reserved. © Specified Controls 2020 Intellectual rights apply.*

**iO HVAC Controls [www.iohvaccontrols.com](http://www.iohvaccontrols.com)**

# LCD Display

Not all display elements or buttons shown may be active. The display is dynamic and functions not applicable will not be shown. The alarm mute button for example, will not be shown until the alarm is sounding.

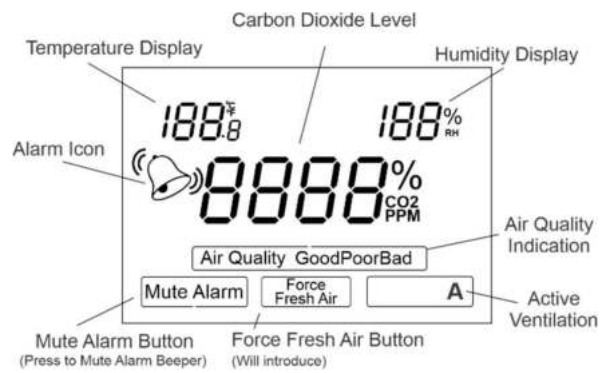

# User Operation

The product requires very little user interaction. It will monitor the levels of carbon dioxide, humidity and temperature within the applied space and is capable of initiating alarms and corrective action if any of these exceed pre-set levels.

When enabled, the user can press the “Force Fresh Air” button which will bring in fresh air. The “Force Fresh Air” button will flash when pressed to indicate that it is running.

When enabled, the LCD backlight can also change the background color from green, amber, and red to visually indicate the CO2 level in the space.



When enabled, user can mute an audible alarm by pressing the “Mute Alarm” button when shown. If Active Ventilation is enabled, the user can tap the “A” icon to briefly display the outside air temperature.

# Terminal Layout

Use a small, flat bladed screwdriver and place it in the bottom center of the enclosure and pry to separate the display from the subbase. Take care not to drop the display as damage may occur.

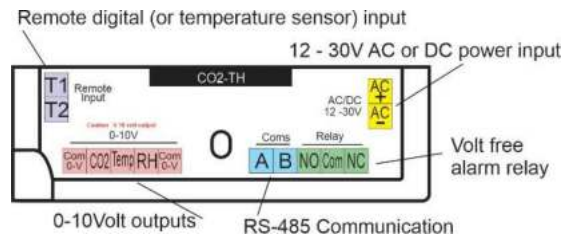

When reattaching, make sure no wiring is interfering with the pin connectors.

Hook the top of the display into the top of the base and swing the lower section in. Press firmly to snap the two halves together. **DO NOT** press on the glass display, press on the plastic only.

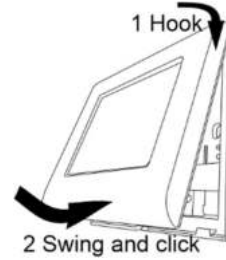

# O-10V Outputs

There are three 0-10V outputs. One each for carbon dioxide, temperature, and relative humidity. All 0-10V output wiring is the same. Wire between the required output and the 0V / Com terminals. The output voltage will increase with increasing temperature, humidity, or carbon dioxide levels. (Default range is 0-2000ppm)

The output voltage and scale for each of the three 0-10V outputs is independently adjustable from the Installer options menu. (See installer options starting on page 16)

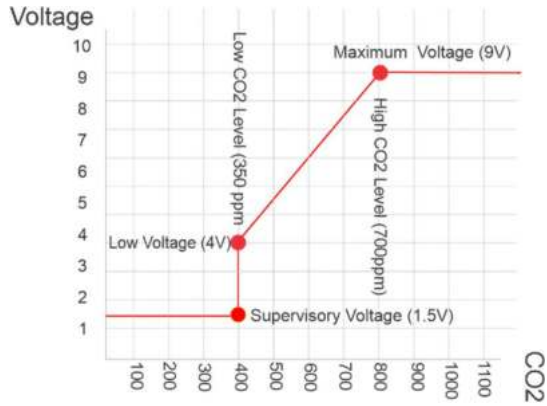

## Relay

There is a single volt free relay with changeover contacts. The relay is rated to carry 30V @1A Max. Any voltage applied to the relay common terminal will switch between the normally open (NO) and normally closed (NC) terminals. This relay can be set to respond to high levels of temperature, relative humidity or carbon dioxide as selected in the installer options. Each sensor has its own selectable alarm threshold.

You can assign just one sensor, such as CO2 to the relay, or multiple sensors such as Temperature and RH to the relay.



The Installer menu options will permit you to set this relay as a normally de-energised or as a fail-safe normally energised relay. This will change the NO/NC wiring logic.

## T1 T2

A single universal input has been provided that will permit several additional functions to be performed. This input can be used as a remote temperature sensor input or as a volt free switch input that can control many functions. A complete list of options available to this input are available in the Installer options menu.



## Power

Primary power can either be AC or DC from 12 to 30V.

AC power is not polarity dependent however if using DC power ensure the positive voltage is applied to the top AC+ terminal and negative to the lower AC- terminal. Reverse polarity DC wiring will not cause damage but will simply will not power on.

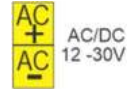

## Communications

This product has isolated RS-485 communications capability. You can select either Modbus RTU or BACnet MSTP communications protocol from within the Installer menu.

For detailed communications capabilities and information on all data points available, separate communications documentation is available



# Power Up

When you first apply power, the LCD will display all elements and then display the firmware version for a few seconds. During the next 180 seconds the display will countdown from 180 to 0 to permit the CO2 and other sensors to stabilize. During this countdown period no alarm conditions will be initiated. All three of the 0-10V outputs will be held at their respective "safety voltage" as defined in the Installer menu (see page 17) and if the alarm relay is set as fail-safe it will energise. The LCD will also cycle its color backlight through green, amber and red.

Once the countdown has reached zero, normal function will begin.

## **Important Notes**

The CO2 sensor has an advanced learning self-calibrating function. This calibration process takes place over an 8-day period. It is therefore essential that power remains constant during this period.

# Installation & Mounting

All sensing devices are contained within the enclosure. Therefore, it is important to locate it within the space to be monitored and controlled.

The monitor should be installed in a location that represents the ambient space temperature. Do not install in an area where drafts are present, near the floor, behind doors or on an external wall.

Avoid mounting in an area where air movement is limited, affected by direct sunlight or other areas not typical of the normal space conditions.

After mounting the subbase, be aware that drafts may travel down wall cavities. It is important to seal the wire access hole to prevent any drafts that might affect the internal sensors.

# Advanced Installer Options Menu

This product can be configured to meet the requirements of the specific application. Within the Advanced Installer options menu, you can adjust how the monitor will respond to and report the levels of carbon dioxide, temperature, and humidity.

Make sure that you understand any changes made in this Installer options menu and if not, contact iO HVAC Controls for clarification and advice.

To enter the Installer menu first tap then press and hold the center of the display. After 10 seconds the display will change and show the digits "15" (fifteen) along the Up / Down arrows and the NEXT button. Use the Up (or Down) arrow to adjust the display to "21" (twenty-one) or your previously saved PIN. Press the NEXT button to enter the menu. If you are returned to the previous screen, you have entered the incorrect PIN. Try again

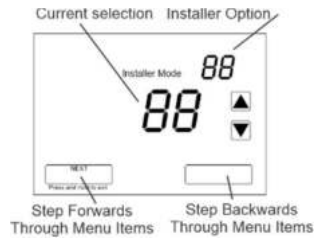

To advance through the menu items tap the “NEXT” button and adjust the shown installer option with the Up / Down arrows.

To exit the Installer menu and save changes press and hold the “NEXT” button for 3 seconds.

After making changes in this menu DO NOT power down for 20 seconds or changes may be discarded.

1	PIN	This sets the PIN to enter the Installer options menu for future entry. Please record any changes made to the PIN as it will affect how you enter the Installer options menu in the future. <u>Default PIN is 21.</u> Range is from 00 to 99.
2	Display Temp	You can display the room Temp in degree C, degree F or hide the display of room temperature. <u>Default is degree Off.</u> Options are C, F or Off.
3	Display RH	You can display or hide the room humidity display. <u>Default is Off.</u> Options are On or Off.
4	Display CO2	You can display the room CO2 in ppm or percentage to alarm point or hide the CO2 display. 0% being displayed is clean fresh air (400ppm) and 100% displayed being at alarm point. <u>Default is ppm.</u> Options are ppm, % or Off.

5	Calibrate Temp	Should you feel that the temperature sensor accuracy has drifted you are permitted to apply a small, fixed offset. <u>Default is 0.0.</u> Options are +/- 5 deg C or F in 0.1 deg steps.
6	Calibrate RH	Should you feel that the humidity sensor accuracy has drifted you are permitted to apply a small, fixed offset. <u>Default is 0%.</u> Options are +/- 25% in 1% steps.
7	Calibrate CO2	Should you feel that the CO2 sensor accuracy has drifted you are permitted to apply a small, fixed offset. <u>Default is 0ppm.</u> Options are +/- 100ppm in 1ppm steps. <b>Caution!</b> The NDIR sensor is extremely stable and accurate. Investigate all other causes for perceived errors before adjusting.
8	Temperature Alarm Relay	You can set a temperature value that will turn on the volt free alarm relay. <u>Default is Off.</u> Options are Off, then -20 to +120 (C or F) in 1-degree steps.
9	RH Alarm Relay	You can set a relative humidity value that will turn on the volt free alarm relay. <u>Default is Off.</u> Options are Off, then 0% to +100% in 1% steps.
10	CO2 Alarm Relay	You can set a carbon dioxide value that will turn on the volt free alarm relay. <u>Default is 800 ppm.</u> Options are OFF, then 400ppm to 2000ppm in 50 ppm steps.

11	Alarm Relay Logic	You can apply the alarm relay as a normally de-energised or as a normally energised (failsafe) relay. If normally energised the alarm relay will energise on power up and de-energise in an alarm condition or loss of power. <u>Default is 0 - Normally de-energised.</u> Options are 0 - Normally de-energised or 1 - Normally energised
12	Beeper	The monitor is fitted with a solid-state beeper. This beeper can be used to acknowledge a button press as well as be used for an alarm. <u>Default is 1 = Beep on button press.</u> Options are 0= No beeper. 1 = Beep on button press. 2 = Beep on alarm. 3 = Beep on button press & alarm.
13	Beeper Mute	The beeper may be set to sound when in alarm condition. If desired, you can show a beeper mute button when this occurs. Default is 0 = Do not permit mute. Options are 1 = Toggle mute. 2 = 1 Hour mute. 3 = 3 Hour mute. 4 = 12 Hour mute.
14	Show Force Fresh Air Button	The SC-CO2-TH display can be set to show a "force fresh air" button. If this button is pressed the CO2 sensor 0-10V output will go to maximum voltage and the alarm relay (if set for CO2) will engage. <u>Default is 2 = Show FFA &amp; auto reset after 1 hour.</u> Options are 1 = Show FFA. 2 = Show FFA & auto reset after 1 hour. 3 = Show FFA and auto reset 4 hours.

15	T1 T2 Input Function	The remote inputs have multiple functions including: 0= Override onboard sensor with remote sensor. 1= Average onboard sensor with remote sensor. 2 = Force fresh air. 3 = Remote mute. 4 = Reserved. 5 = Report status to Modbus/BACnet. 6 = Outside air sensor. 7 = Pause all alarms (Unoccupied). <u>Default is 0.</u>
16	Active Ventilation High Outside Air Temperature Lockout	The Active Ventilation function uses the inside and outside (if fitted) air temperature sensors to determine if outside air is suitable to be used to ventilate the room. The outside air temperature must be under this value to be deemed suitable for the Active Ventilation function to operate. <u>Default is OFF.</u> Adjustments are Off, then 5 degrees to 100 degrees in 1-degree steps.
17	Active Ventilation Low Inside Air Temperature Lockout	The Active Ventilation function uses the inside and outside (if fitted) air temperature sensors to determine if outside air is suitable to be used to ventilate the room. This setting defines the inside air temperature threshold that if exceeded (and if outside air is suitable) will begin the Active Ventilation function. <u>Default is Off.</u> Options are Off, then 5 degrees to 100 degrees in 1-degree steps.

18	Active Ventilation Output	The monitor can introduce fresh outside air into the room when conditions are suitable. This option defines the output(s) that control this function. The letter "A" will be shown on the display when this function is enabled and flash when it is working. (Tap the "A" to see outside temp) <u>Default is 0 = Function Off.</u> Options are 0= Function Off. 1 = Relay only. 2 = Temp 0-10V only. 3 = Relay and temp 0-10V.
19	Temp Min Value	This option permits you to select the lowest temperature value to be used. Temperatures below this value will be ignored. (See graph on page 6) <u>Default is 0 degrees.</u> Adjustments are -20 degrees to 150 degrees (C or F) in 1-degree steps.
20	Temp Max Value	This option permits you to select the highest temperature value to be used by the SC-CO2-TH. Temperatures above this value will be ignored. (See graph on page 5) <u>Default is 100 degrees.</u> Adjustments are -20 degrees to 150 degrees in 1-degree steps.
21	Temp Low Voltage	This sets the minimum temperature 0-10V output voltage when at the minimum temperature value. (See graph on page 5) <u>Default is 0V.</u> Adjustments are 0-10V in 0.5V steps.
22	Temp Max Voltage	This sets the maximum temperature 0-10V output voltage when at the maximum temperature value. (See graph on page 5) <u>Default is 10V.</u> Adjustments are 0-10V in 0.5V steps.



23	Temp Safety Voltage	This sets a constant voltage to the temperature 0-10V output. This voltage will be present whenever the SC-CO2-TH is powered. (See graph on page 5) <u>Default is 0V.</u> Adjustments are 0-10V in 0.5V steps.
24	RH Min Value	This option permits you to select the lowest RH value to be used by the SC-CO2-TH. RH below this value will be ignored. (See graph on page 5) <u>Default is 0 RH.</u> Adjustments are 0 to 100 in 5% steps.
25	RH Max Value	This option permits you to select the highest RH value to be used by the SC-CO2-TH. RH above this value will be ignored. (See graph on page 6) <u>Default is 100%.</u> Adjustments are 0 to 100% in 5% steps.
26	RH Low Voltage	This sets the RH 0-10V output minimum voltage when at the minimum RH value. (See graph on page 6) <u>Default is 0V.</u> Adjustments are 0-10V in 0.5V steps.
27	RH Max Voltage	This sets the RH 0-10V maximum output voltage when at the maximum RH value. (See graph on page 6) <u>Default is 10V.</u> Adjustments are 0-10V in 0.5V steps.
28	RH Safety Voltage	This sets a constant voltage to the RH 0-10V output. This voltage will be present whenever the SC-CO2-TH is powered. (See graph on page 6) <u>Default is 0V.</u> Adjustments are 0-10V in 0.5V steps.

29	CO2 Min Value	This option permits you to select the lowest CO2 value to be used by the SC-CO2-TH. CO2 levels below this value will be ignored. (See graph on page 6) <u>Default is 800ppm.</u> CO2 Adjustments are 0 to 2000ppm in 50ppm steps.
30	CO2 Max Value	This option permits you to select the highest CO2 value to be used by the SC-CO2-TH. CO2 levels above this value will be ignored. (See graph on page 6) <u>Default is 900ppm.</u> Adjustments are 0 - 2000ppm in 50ppm steps.
31	CO2 Low Voltage	This sets the CO2 0-10V output minimum voltage when at the minimum CO2 value. (See Graph on page 5) <u>Default is 2V.</u> Adjustments are 0-10V in 0.5V steps.
32	CO2 Max Voltage	This sets the CO2 0-10V maximum output voltage when at the maximum CO2 value. (See graph on page 5) <u>Default is 10V.</u> Adjustments are 0-10V in 0.5V steps
33	CO2 Safety Voltage	This sets a constant voltage to the CO2 0-10V output. This voltage will be present whenever the SC-CO2-TH3 is powered. (See graph on page 5) <u>Default is 0V.</u> Adjustments are 0-10V in 0.5V steps.
34	Back light	The back light can be set to provide an indication of the current air quality by changing colour from green to amber to red or simply illuminate the display in green when a button is pressed. <u>Default is 2.</u> Options are 0 = No Back light. 1 = Alarm. 2 = Button press only.

35	Amber Temp Backlight Threshold	This option sets the threshold of where the backlight turns from green to amber for temperature. <u>Default is Off.</u> Options are Off, then 0 to 100 degrees in 1-degree steps.
36	Red Temp Backlight Threshold	This sets the threshold of where the backlight turns from amber to red for high temperature. <u>Default is Off.</u> Options are Off, then 0 to 100 degrees in 1- degree steps.
37	Amber RH Backlight Threshold	This sets the threshold of where the backlight turns from green to amber for humidity. <u>Default is Off.</u> Options are Off, then 0 to 100 % in 1 % steps.
38	Red RH Backlight Threshold	This sets the threshold of where the backlight turns from amber to red for high temperature. <u>Default is Off.</u> Options are Off, then 0 to 100 % in 1 % steps.
39	Amber CO2 Backlight Threshold	This sets the threshold of where the backlight turns from green to amber for high carbon dioxide. <u>Default is Off.</u> Options are Off, then 0 to 2000 ppm in 50ppm steps.
40	Red CO2 Backlight Threshold	This sets the threshold of where the backlight turns from amber to red for high carbon dioxide. <u>Default is Off.</u> Options are Off, then 0 to 2000 ppm in 50ppm steps.

41	Communication Protocol	The monitor has an isolated RS-485 communications capability. You can select ModBus RTU or BACnet MSTP communications protocol. The full stop in the temperature display will flash if communications are running. <u>Default is 0 = Modbus.</u> Options are 0 = Modbus. 1 = BACnet.
42	Communications Speed	This option permits you to define the communications speed for the selected communications protocol. <u>Default is dependent on protocol selected.</u>
43	Communications Parity	Communications protocols require a parity to be set. <u>Default is dependent on protocol selected.</u> Options are 0 = None. 1 = Odd. 2 = Even.
44	Communications Address	This setting defines the communications address on the network as used by the monitor. <u>Default is 7.</u> Adjustments are 1 to 127.
45	CO2 Sensor Response speed	The NDIR sensor fitted to the monitor can respond to changing CO2 levels very rapidly. If the sensor is in a location where it is very close to people, exhaled breath directly onto the sensor can cause rapid spikes in CO2 readings which may not be typical of general Indoor Air Quality levels. <u>Default is 2.</u> Adjustments are 1, 2 & 3 with 3 being slowest.
46	Air Quality Display	The LCD will either display the air quality or can be turned off. On = Display Air Quality and Off = No Air Quality Display. <u>Factory default is Off.</u>

47	CO2 Relay OFF Threshold	This value permits you to define, in PPM, how far from the CO2 Alarm point the alarm will deactivate. Default is 20ppm. Adjustable from 20 to 1000ppm.
r	Reset	Setting this value to 1 then exiting the installer menu will factory reset the monitor.

## Typical Wiring Examples

The following contains wiring examples that may be helpful in setting up the monitor for your specific application. These wiring examples may require adjusting various options in the Installer menu. For example, if the volt free relay is used to control a 24V power open / closed damper based on CO2 levels, you must activate and define the CO2 Relay Alarm on page 13.

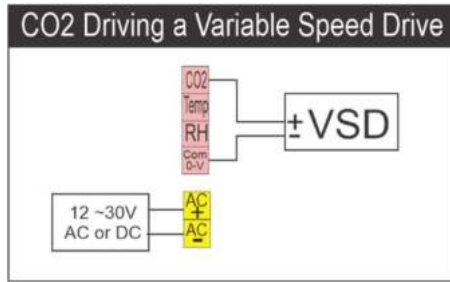

In this example a standard Variable Speed Drive is being controlled with the CO2 0-10V output. The Installer menu permits you to scale the 0-10V output to match your requirements such as output 0V at 450ppm and output 10V at 800ppm.

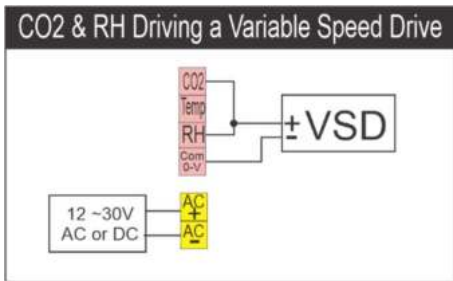

In this example the CO2 and RH is controlling the VSD with a high select. Both the CO2 and RH outputs are individually scalable so the CO2 range can be 450ppm to 1,000ppm and the RH range can be 75% to 100%. Also, the RH output can be limited to 7V max if required.

Whether you wish to control a Variable Speed Drive or a modulating damper the wiring and setup are the same. You can also mix the devices you wish to control with the three 0-10V outputs. All three outputs can be individually scaled.

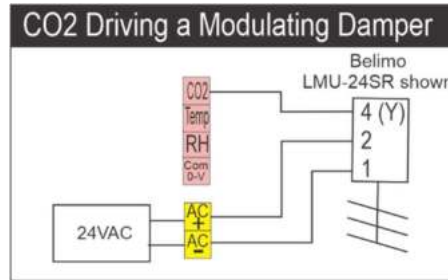

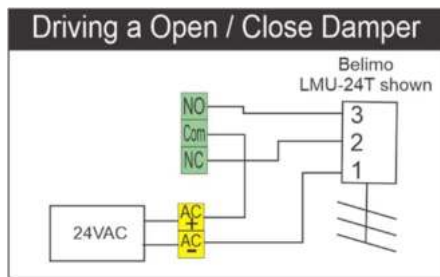

An open/close or an off/on output can be controlled by the monitor using the volt free relay provided. The relay threshold can be individually adjusted for each sensor. (30V @ 1A max)

#### Active Ventilation Function

By fitting an outside air sensor, the monitor can bring in fresh air to improve room air quality if the outside air temperature is suitable.

To use this function, you must first fit an outside air temperature sensor such as the RS-01/2 or RS1D to the monitor T1 & T2 terminals.

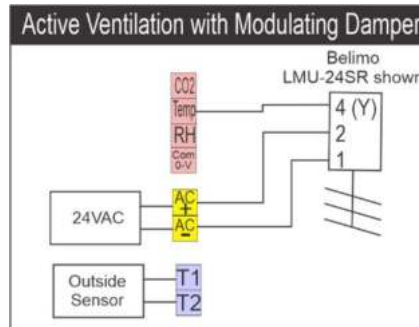



In the Installer menu you must activate the Active Ventilation function by setting the inside and outside air temperature thresholds (page 15 explains this) and defining the active ventilation output options. Once you have completed these three steps the letter "A" will be shown in the lower right corner of the LCD to confirm the Active Ventilation function is active.

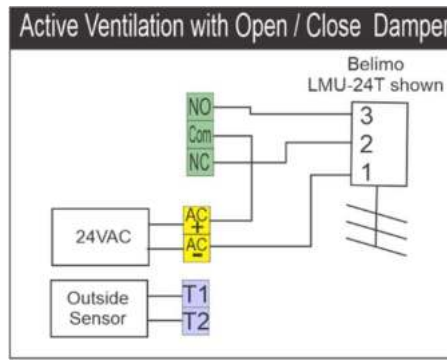

If selected in the Active Ventilation options menu, the monitor will modulate the temperature 0-10V output so that the output is at the maximum voltage set when the room temperature is 1 degree above the inside temperature setpoint. If introducing outside air the icon "A" will flash on the LCD. Tapping the "A" icon will briefly show the outside air temperature.

Should you wish, you can also have the volt free relay used for active ventilation by selecting it in the Active Ventilation Output options menu.

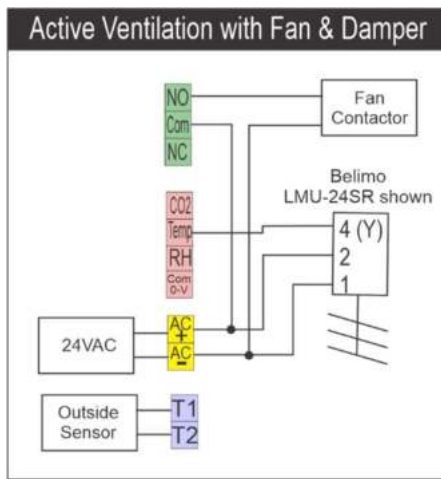

If you would like, you can have both the temperature 0-10V output and volt free relay used for advanced ventilation. In the Active Ventilation Output options menu settings select both relay and temp 0-10 (option 3). This permits you to open the fresh air damper and turn a fan on for example if outside air is suitable.

This function runs in parallel to any alarm function using these same output(s).

The Advanced Ventilation option is independent of the alarm and

functions of the monitor. This function will not sound any audible alarm or impact the LCD color. The letter "A" will simply flash in the lower right corner of the LCD to show the function is running.

# Specifications

Power	12 to 30V AC or DC
Relay Output	30V AC/DC @ 1A Max
Touch Method	"XY" Resistive
Back Light	Multicolor LED (Green, Red, Amber)
Back Light Life	40,000 Hours to Half Intensity
Operating Temperature	23°F To 122°F
Operating RH	0 To 95% (Non-Condensing)
0-10V Outputs	5ma Max
Temperature Sensor Range	-4 - +122F
Temp Sensor Accuracy	+/- 3% at 77°F
RH Sensor Range	0 to 95% RH
RH Sensor Accuracy	+/-3% at 77°F (30% to 80% RH)
CO2 Sensor Range	0-2000ppm
CO2 Sensor Accuracy	+/- 40ppm at 77°F
Warranty	3 Years RTB
Approvals	CE & Ctick
Communications	Modbus RTU 4.8 / 9.6 / 19.2 / 38.4k BACnet MSTP 38.4 to 512k
Size	4.5" W x 4.125" H x 1" D





[www.iohvaccontrols.com](http://www.iohvaccontrols.com)

For Technical Support Call Toll Free: 866-225-5032

iO-06-1347-092222

Page 29