

INSTALLATION INSTRUCTIONS

Series 40 Corridor Damper

General Notes:

Corridor Dampers are intended for use where air ducts penetrate or terminate at horizontal openings in the ceilings of interior corridors, as defined in the Uniform Building Code or where permitted by the Authority Having Jurisdiction. These dampers have been evaluated for, and are intended for installation only in specific corridor ceiling constructions as defined in these installation instructions. These dampers are for use as a fire/smoke damper where air ducts penetrate or terminate at horizontal openings in the ceilings of internal corridors. Dampers are set to fail closed on loss of power. Dampers may be installed such that the actuator is above or below the damper.

These installation instructions apply to tunnel corridor dampers installed in 1-hour rated drywall fire separations. These combination fire and leakage rated dampers are designed to operate in ceiling penetrations of tunnel corridors with blades running horizontally. To insure optimum operation and performance, the damper must be installed so that it is free from racking. Do not compress or stretch the damper frame into the duct or opening. Installation must be performed in accordance with NFPA 90A, local and national codes and in ceiling constructions only where permitted by Authority Having Jurisdiction.

Single-Section Maximum:

Model 40V - 3V Crimped Blades:
Horizontal: 24"W x 24"H

Opening Preparation:

1. The opening shall be enlarged by a minimum of 1/16" per linear foot of both damper width and height to allow for thermal expansion. Maximum opening size shall not exceed 1/2" larger than damper or sleeve assembly
2. Damper is furnished 1/4" smaller than the given opening dimensions without sleeve

General Installation:

As described in NFPA 90A and as defined by the appropriate SMACNA duct construction standard, the sleeve gauge shall be equal to or heavier than the gauge of the duct when one or more of the following duct connections are used: plain s-slip, hemmed s-slip, standing s-slip, reinforced standing s-slip, inside slip joint, and double s-slip. The damper is fastened to the sleeve with 1/2" welds spaced 6" center-to-center. If any duct-damper connections are used other than the ones previously described, a separate sleeve must be fabricated as follows. The maximum thickness for a sleeve shall be 0.138" for coated steel (0.135" for uncoated). It also must be at least 0.56" thick for coated steel (0.053 for uncoated).

A bead of Dow-Corning® 100% silicone rubber, Dow-Corning® Silastic 72 or GE RTV 108 sealant shall be applied between the damper and sleeve in the same manner. Only one side of the damper requires caulking. Note: the sealant is not required when dampers are supplied for fire damper applications only and are not required to be leakage rated.

Damper sleeve shall not extend beyond the fire wall more than 6" on one side and 16" on the opposite side for actuator mounting and/or access doors. The sleeve may extend 16" on both sides of the fire wall if an access door is installed on one side and the actuator on the other side.

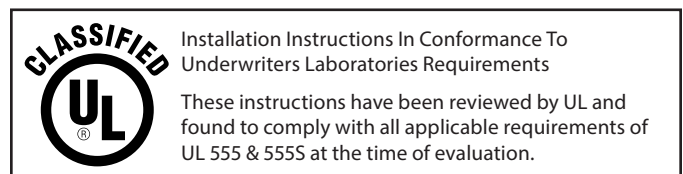
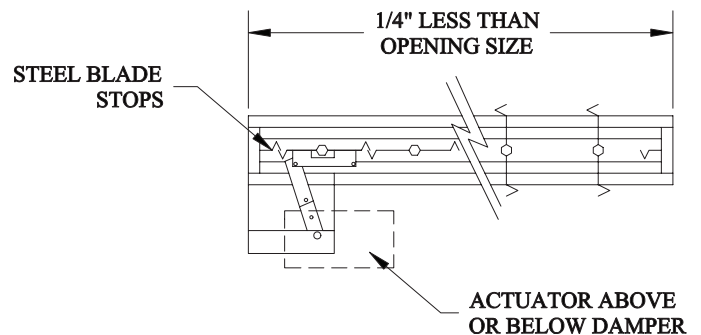
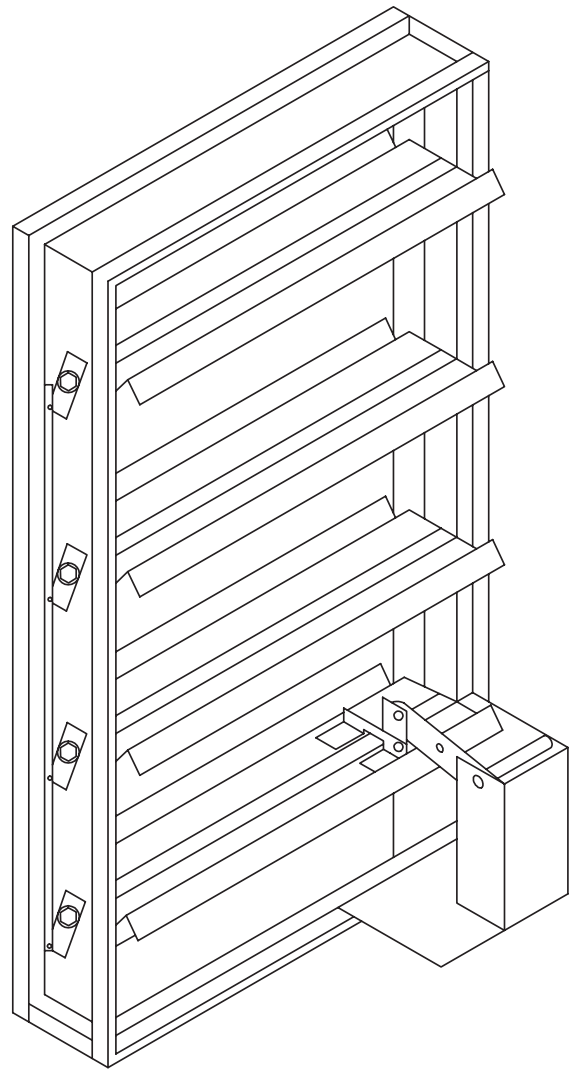

ALL INSTALLATIONS ARE SUBJECT TO LOCAL AUTHORITY APPROVAL PRIOR TO ORDERING DAMPERS AND DAMPER INSTALLATION

INSTALLATION INSTRUCTIONS

Mounting Details:

There are three different ways the damper may be mounted. The opening should be prepared as shown in the drawings depicting Wood Stud Construction or Steel Stud Construction. Dampers may be mounted with the actuator above or below the plane of the blades. The plane of the blades in the closed position cannot be more than 12" away from the surface of the ceiling. Wood stud construction is shown. Installation in steel studs is similar but the opening needs not to be lined with gypsum and screws may be 1-1/2" long.

Ceiling Construction:

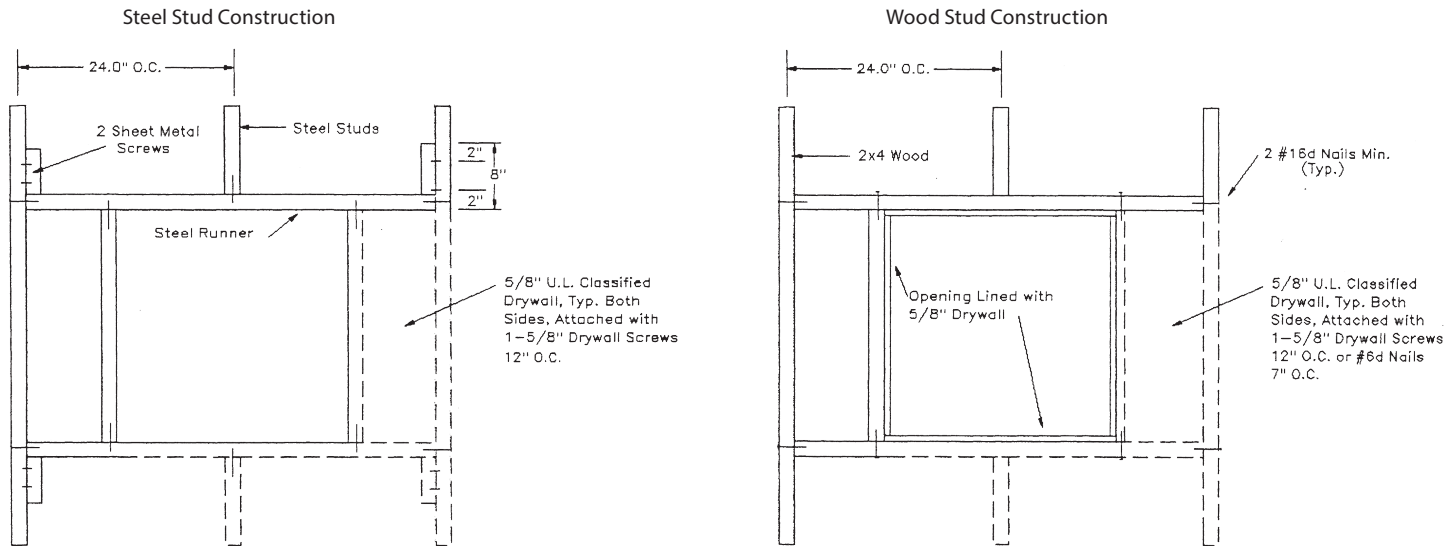

Method 1:

No perimeter retaining angles are required. This application is for ductwork to penetrate one side of the wall and a grille on the other side. This method required 1-1/2" or 2" drywall screws (depending on ceiling construction) to be screwed through the sleeve into the box frame around the hole. Screws are to be on 6" centers and a maximum of 3" from the ends. A 3/4" grille mounting flange may be field applied with #10 bolts or screws, 3/16" rivets or 1/2" welds to the sleeve.

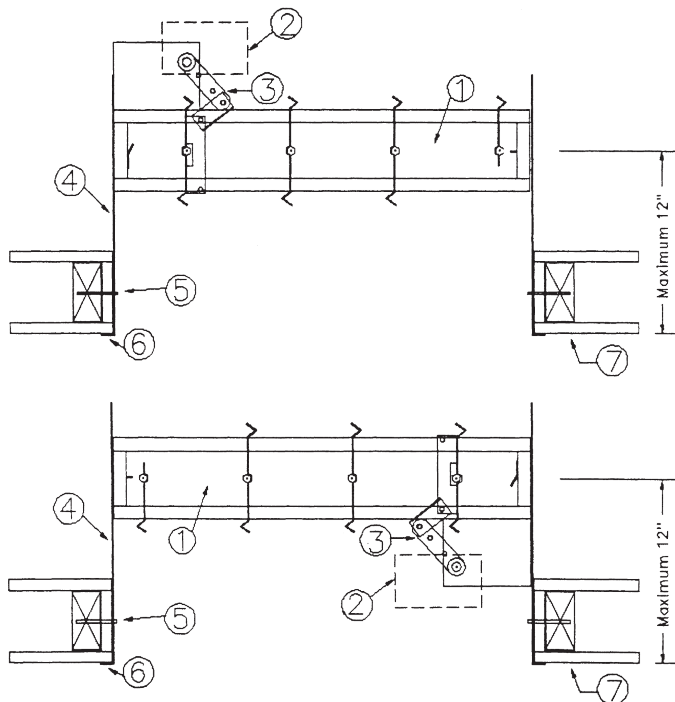

1. Model 41 or 42 Damper
2. Actuator/Motor
3. Fusible Link
4. Sleeve
5. 2" Drywall Screws – 6" max. o.c., 3" max from corners. Screws to be set so as not to distort damper.
6. 3/4" flange for grille to be mounted. Flange may be part of sleeve or mounted in field with #10 bolts or screws, 3/16" rivets, or 1/2" welds spaced 6" max. o.c.
7. Ceiling construction – see separate detail for proper construction.
8. 1-1/2" x 1-1/2" x 16 ga. St. retaining angles mounted with #10 bolts or screws, 3/16" rivets, or 1/2" welds spaced 6" max. o.c.
9. 3/4" x 2-1/4" x 16 ga. St. retaining angles mounted with #10 bolts or screws, 3/16" rivets, or 1/2" welds spaced 6" max. o.c.

INSTALLATION INSTRUCTIONS

Method 2:

This method uses retaining angles above and below the fire partition when the application is for ductwork to penetrate one side of the wall and a grille on the other side. This method requires 1-1/2" x 1-1/2" x 16 gauge retaining angles on one side and 3/4" x 2-1/4" x 16 gauge retaining angles on the other side. The retaining angles may be attached with #10 bolts or screws, 3/16" rivets or 1/2" welds to the sleeve. Fasteners are to be on 6" centers and a maximum of 3" from the ends.

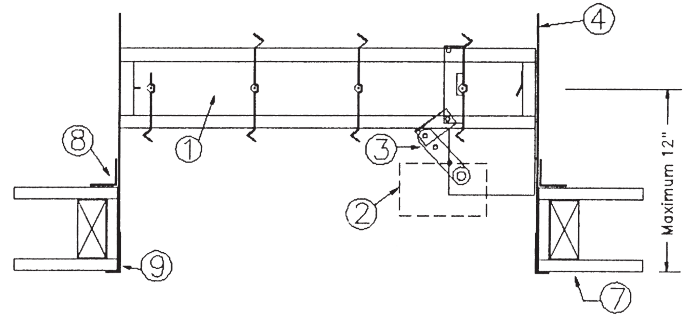
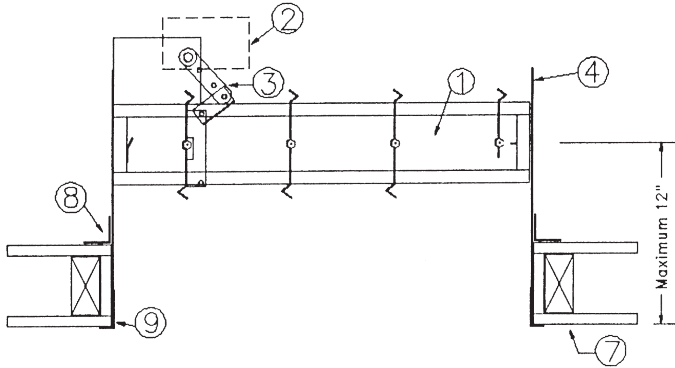

Method 3:

This method uses retaining angles above and below the fire partition when a duct passes completely through. This method requires 1-1/2" x 1-1/2" x 16 gauge retaining angles on one side and 3/4" x 2-1/4" x 16 gauge retaining angles on both sides of the fire partition. The retaining angles may be attached with #10 bolts or screws, 3/16" rivets or 1/2" welds to the sleeve. Fasteners are to be on 6" centers and a maximum of 3" from the ends.

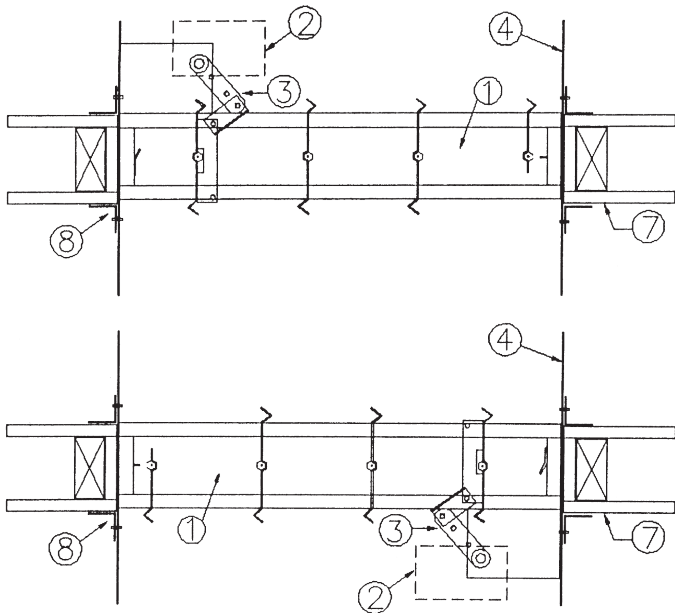

1. Model 41 or 42 Damper
2. Actuator/Motor
3. Fusible Link
4. Sleeve
5. 2" Drywall Screws – 6" max. o.c., 3" max from corners. Screws to be set so as not to distort damper.
6. 3/4" flange for grille to be mounted. Flange may be part of sleeve or mounted in field with #10 bolts or screws, 3/16" rivets, or 1/2" welds spaced 6" max. o.c.
7. Ceiling construction – see separate detail for proper construction.
8. 1-1/2" x 1-1/2" x 16 ga. St. retaining angles mounted with #10 bolts or screws, 3/16" rivets, or 1/2" welds spaced 6" max. o.c.
9. 3/4" x 2-1/4" x 16 ga. St. retaining angles mounted with #10 bolts or screws, 3/16" rivets, or 1/2" welds spaced 6" max. o.c.

INSTALLATION INSTRUCTIONS

Wiring Diagram

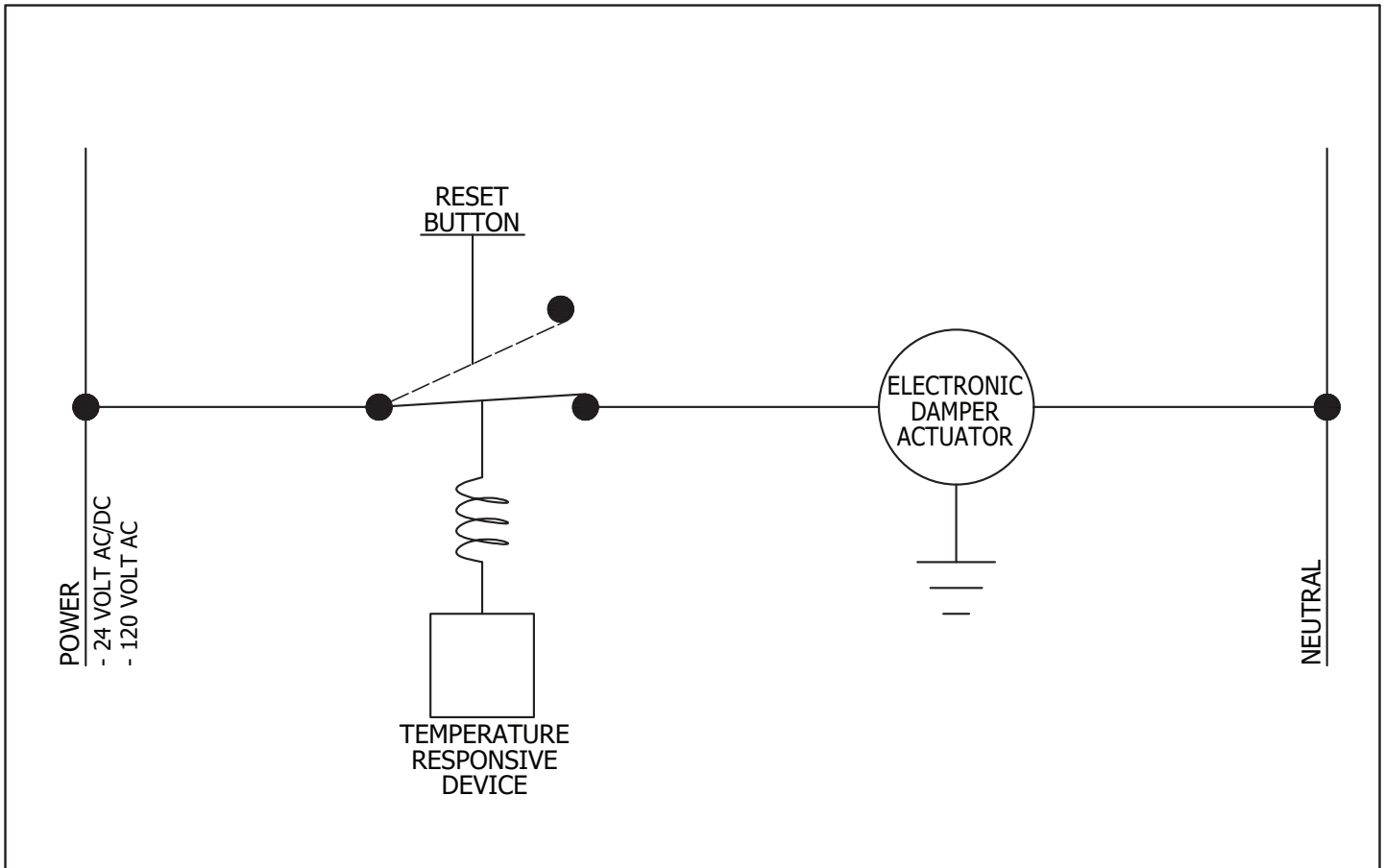

Actuators:

Aire Technologies' combination fire & smoke dampers are equipped with factory-installed actuators which operate on the detection of heat or loss of actuator power.

Once damper is installed, it must be cycled several times to ensure proper function.

WARNING – do not open actuator housing!

Access:

Suitable access shall be provided for damper inspection and service. Where it is not possible to achieve sufficient size access, it will be necessary to install a removable section of duct.



Installation Instructions In Conformance To
Underwriters Laboratories Requirements

INSTALLATION INSTRUCTIONS

Maintenance:

Dampers shall be maintained in intervals as stated in NFPA 90A, Appendix B, unless local codes require more frequent inspections. Check the fuse link, stainless steel closure springs where furnished, cycle damper, check for free operation and complete closure, clean with mild detergent or solvent, and secure damper open with fusible link.

Remote/Resettable Operator for Fire/Smoke Dampers: Models TTD, STD & BIP:

In conventional HVAC systems, the fan is designed to shut off in case of fire or smoke alarm. Engineering advancements have been developed for smoke removal. In engineered smoke control systems, fans remain on and necessary dampers are opened or closed to safely evacuate smoke from a building.

Model TTD allows a fire fighter to override the primary temperature sensor (165°F or 212°F) or smoke alarm and open a closed damper from a master control panel. Model STD allows dampers to be easily tested and reset at the actual damper location. Both models are reusable thermal links which are reset by simply pushing the reset button on the damper (no fusible link to maintain and replace). Each damper is equipped with an electric actuator as an integral component.

Model TTD (Two Thermal Disk) Application:

Fire/Smoke dampers have had the conventional fusible link replaced with a primary temperature sensor (165°F or 212°F) and secondary sensor (250°F or 350°F). Once the temperature in the ductwork reaches the setting of the primary link or a smoke detector sends a signal, the damper closes. At this point, the damper remains closed until the primary sensor is bypassed at the control panel. Once the primary sensor is bypassed, the damper will open and remain open until the temperature reaches the setting of the secondary sensor. Once that sensor has tripped, it may then only be reset at the damper installation site.

Model STD (Single Thermal Disk) Application:

There are situations in which the damper needs to be periodically checked for operation. In this case, the damper may be checked by heating the sensor above its operating temperature, thus shutting the damper. After 1 minute, the sensor may be manually reset, opening the damper. This allows checking the damper without shutting the entire system down.

Model BIP (Blade Indicator Package) Application:

Micro-switches are controlled through cams on the control shaft to indicate the blade position. The micro-switches are then hooked to lights (open and closed) on the control panel. A fire fighter uses these lights to determine which dampers are closed and which are open. These lights will also help detect the proximity of the fire.

UL 555S rated for Leakage Class I, II, and III

UL 555 rated for 1-hour rating

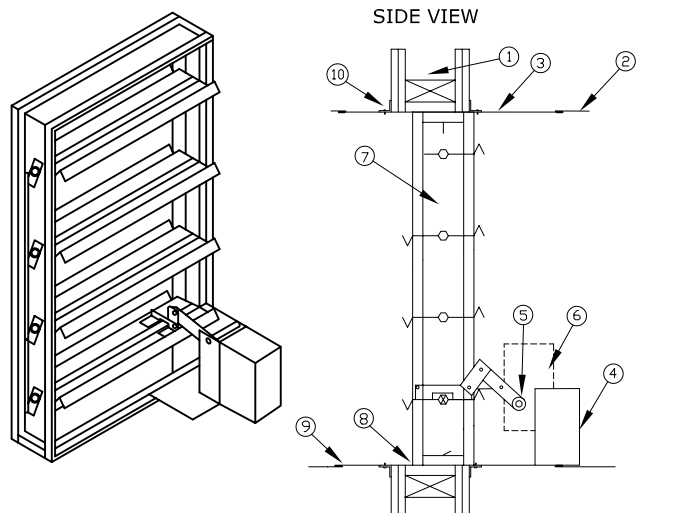
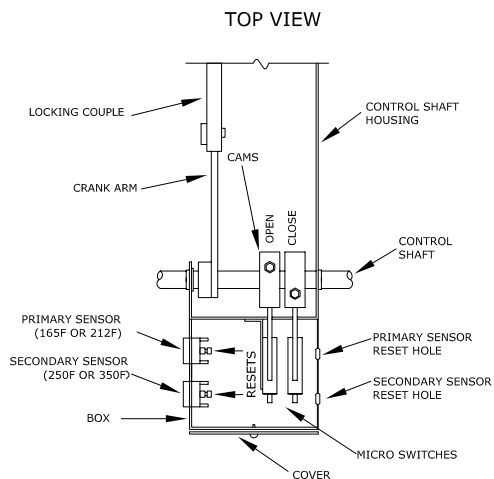

ITEM	DESCRIPTION
1.	Fire Wall
2.	Duct Sleeve
3.	Sleeve
4.	TTD, STD, and/or BIP
5.	Control Shaft
6.	Operator/ Actuator
7.	Damper Frame
8.	Caulking Material
9.	Slip Joint, Sleeve to Duct
10.	Retaining Angles



Installation Instructions In Conformance To Underwriters Laboratories Requirements

Model B.I.P. Operation

The blade indicator package denotes when the damper is open or closed at the control panel. Wire as shown in Figure 1. When properly wired and damper, in open position, the “open” light on control panel will be lit. If power is disconnected to the actuator, the damper closes. Then the “closed/shut” light on the control panel becomes lit up. Cycle the damper a minimum of three cycles to ensure proper operation.

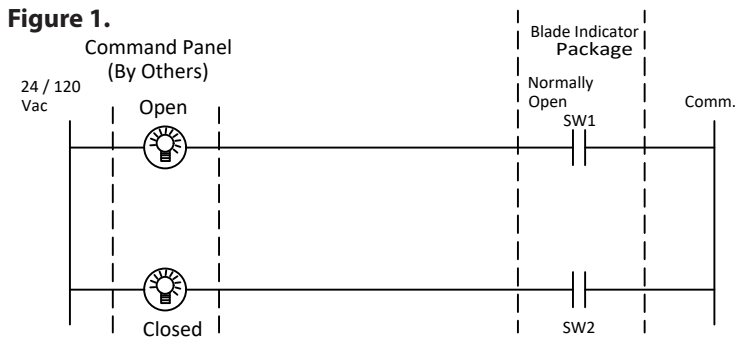

Model S.T.D. Operation

The single thermal disk is used in lieu of a conventional fusible link. Wire an electric operator as shown in Figure 2. Wire a pneumatic actuator as shown in Figure 3. To check operation, open damper. Now heat the sensor disk above its set temperature (usually 165 °F or 212 °F). At this time damper should close. Allow sensor to cool (usually 1 - 3 minutes). Using a wood dowel rod (3/16 – 1/4” Dia), place it in the approximate hole on opposite side of the sensor housing (through sleeve). Push it until you hear a click, which resets the thermal sensor. At this time, the damper should reopen. Do not touch face of sensor, because it will destroy calibration of sensor.

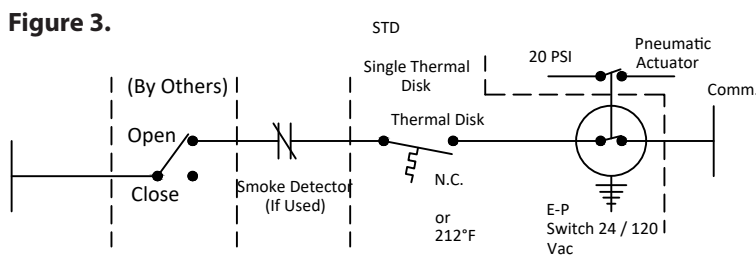
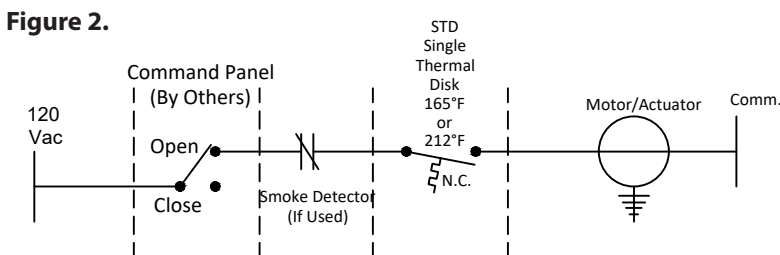

SW1 and SW2 Switch Amp Ratings
 10 Amp, 1/3 HP, 125 or 250 Vac
 0.25 Amp, 250 VDC, 0.5 Amp, 125 V

Model T.T.D. Operation

The two thermal disk system is used in engineer smoke control system. The dampers are wired so that after a smoke detector signal or the primary thermal disk trips and shuts the damper, the damper then can be reopened, until the temperature in the duct reaches the secondary disk temperature. After the temperature passes the secondary temperature setting, the damper will close and cannot be opened. Wire an electronic actuator as shown in Figure 4. Wire a pneumatic actuator as shown in Figure 5. To check operation, open damper. Now heat the lower sensor (closest to the bottom of the damper) above its sensor temperature (usually 165°F or 212°F). The damper should close after you hear a click. Go to the control panel and switch the damper to by-pass. At this time, the damper should open up. Now heat the upper sensor (one away from bottom of sleeve) above its operating range (usually 250°F or 350°F). After you hear a click, the damper will close. Allow sensors to cool (usually 1 – 3 minutes). Using a wood dowel rod (3/16 – 1/4" Dia), place it in the approximate holes on the opposite side of the sensor housing box (through sleeve). Push it until you hear a click, which resets the thermal sensor. After resetting both sensors, the damper should open. Do not touch face of sensor because it will destroy calibration of the sensor. Return to the control panel and place switch to normal operating position.

Figure 4.

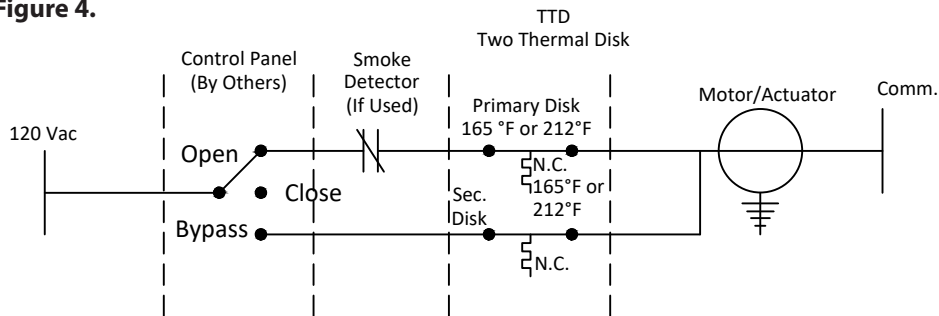
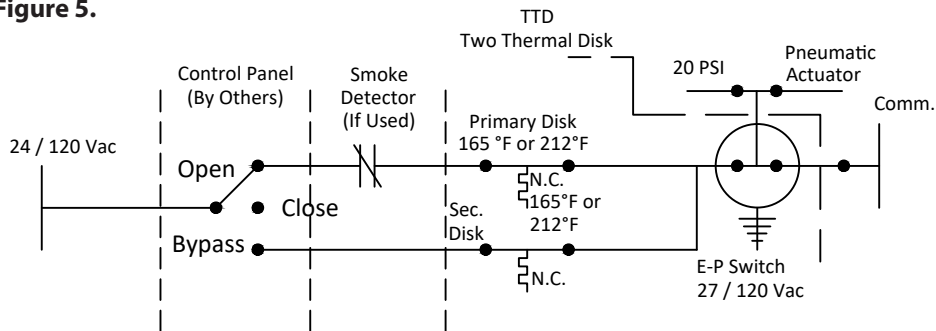

Figure 5.



Model S.T.D. With B.I.P. Operation

Wire electric actuators as shown in Figure 6. Wire pneumatic actuators as shown in Figure 7. Refer to Model B.I.P. Operation and Model S.T.D. Operation for proper operations and checking procedures.

Figure 6.

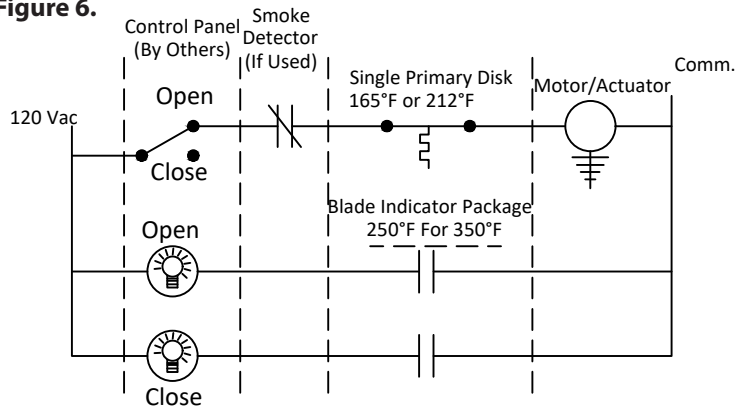
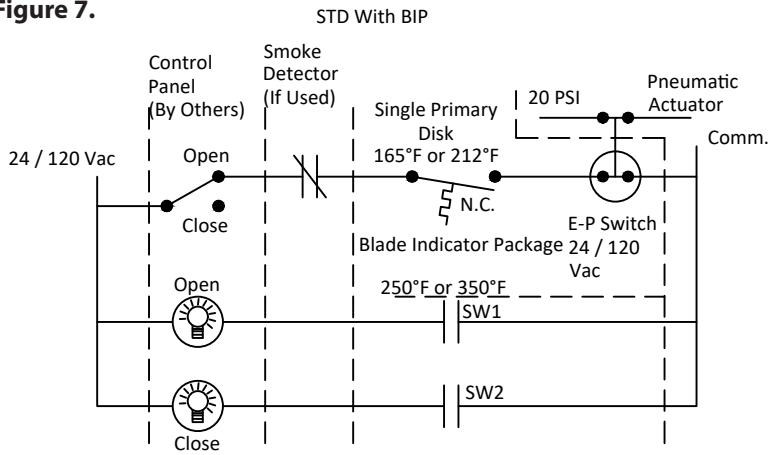

Figure 7.



Model T.T.D. with B.I.P. Operation

Wire Electric Actuators as shown in Figure 8.

Wire Pneumatic Actuators as shown in Figure 9.

Refer to Model B.I.P. Operation and Model T.T.D. Operation for proper operation and checking procedures.

