

INSTALLATION INSTRUCTIONS

Supplemental Installation Instructions for Mounting Out of Plane of Wall

The installation instructions are for mounting of dampers out of the plane of the wall. A framed wall opening detailed below are for walls constructed of metal studs and gypsum wallboard having a resistance rating of 2 hours or less. A framed wall opening is detailed below. The gypsum wall board shall be fastened 12" on center to all stud and runner flanges surrounding opening. The same installation may be used for masonry or block walls using a minimum of 1-1/2" long steel concrete anchors of a minimum diameter of 0.145". All construction and fasteners shall meet the requirements of the appropriate wall design (see UL Fire Resistance Directory). The approved Combination Fire and Smoke Dampers for this application are 11VOW, 12VOW, 13VOW, 11FOW, 12FOW, and 13FOW.

Single-Section Maximums:

Model 10VOW - 3V Crimped Blades Out Of Wall Damper:

Vertical Max: 36"W x 36"H

Model 10FOW - Airfoil Blades Out Of Wall Damper:

Vertical Max: 36"W x 36"H

The damper is to be positioned so that when in the closed position, the blades are a maximum of 10" from the wall. If retaining angles are used to secure the sleeve to the wall, 1/2" welds, No. 10 sheet metal screws, 1/4" nut and bolts, or 3/16" steel pop rivets shall be used at 10" on center to secure them to the sleeve. The angles may or may not be attached at the corners. The gauge of the sleeve may be the same as the gauge of the duct, if SMACNA duct connections are used (see page M-3).

The maximum thickness of the sleeve shall be 16 gauge steel (0.070" coated). The minimum thickness of the sleeve shall be 20 gauge steel (0.035" coated). The connecting ducts shall not be continuous, but shall terminate at the sleeve or frame. The damper shall be retained in the wall in one of two ways: Duct Continues or Grille Mounts (both shown below). The damper must be ordered from the factory as a fire/smoke damper out-of-wall type.

Framed Wall Opening

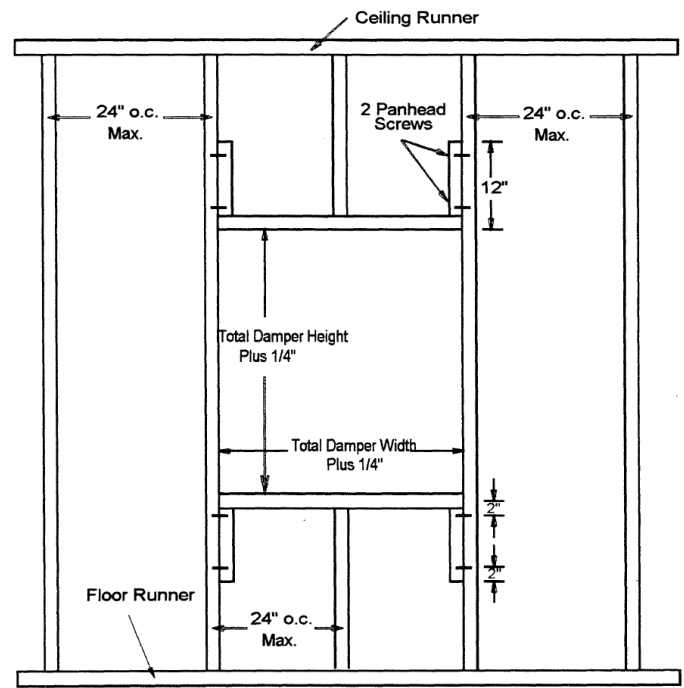

Grille Mount

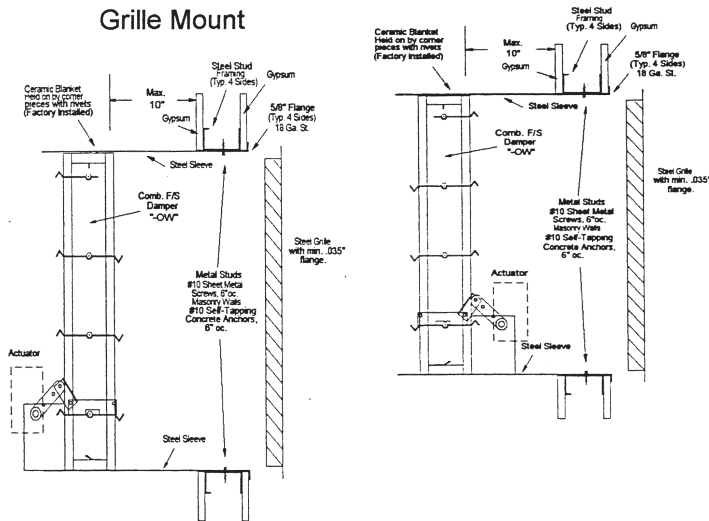

Duct Continues

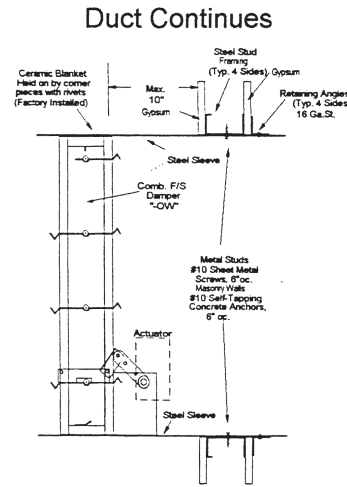

Duct Continues

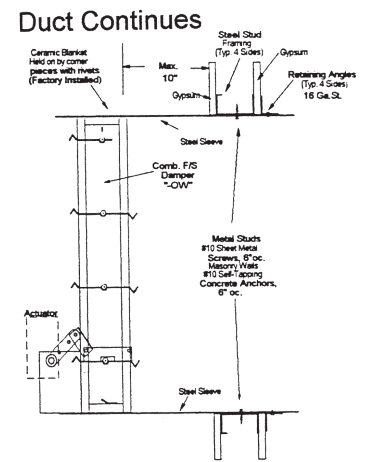

Damper sleeve shall not extend beyond the fire wall more than 6" on one side and 16" on the opposite side for actuator mounting and/or access doors. The sleeve may extend 16" on both sides of the fire wall if an access door is installed on one side and the actuator on the other (this is not recommended).



Installation Instructions In Conformance To Underwriters Laboratories Requirements

INSTALLATION INSTRUCTIONS

Supplemental Installation - Optional Sealing of Dampers in Fire Rated Walls or Floor Openings

The need to seal between retaining angles and sleeves and/or between retaining angle and fire partition is not required by Underwriters Laboratories. Aire Technologies is UL-approved without the use of any sealant. However, if a tight seal is specified or required in the area of penetration through the fire partition, below will provide proper directions for sealing opening.

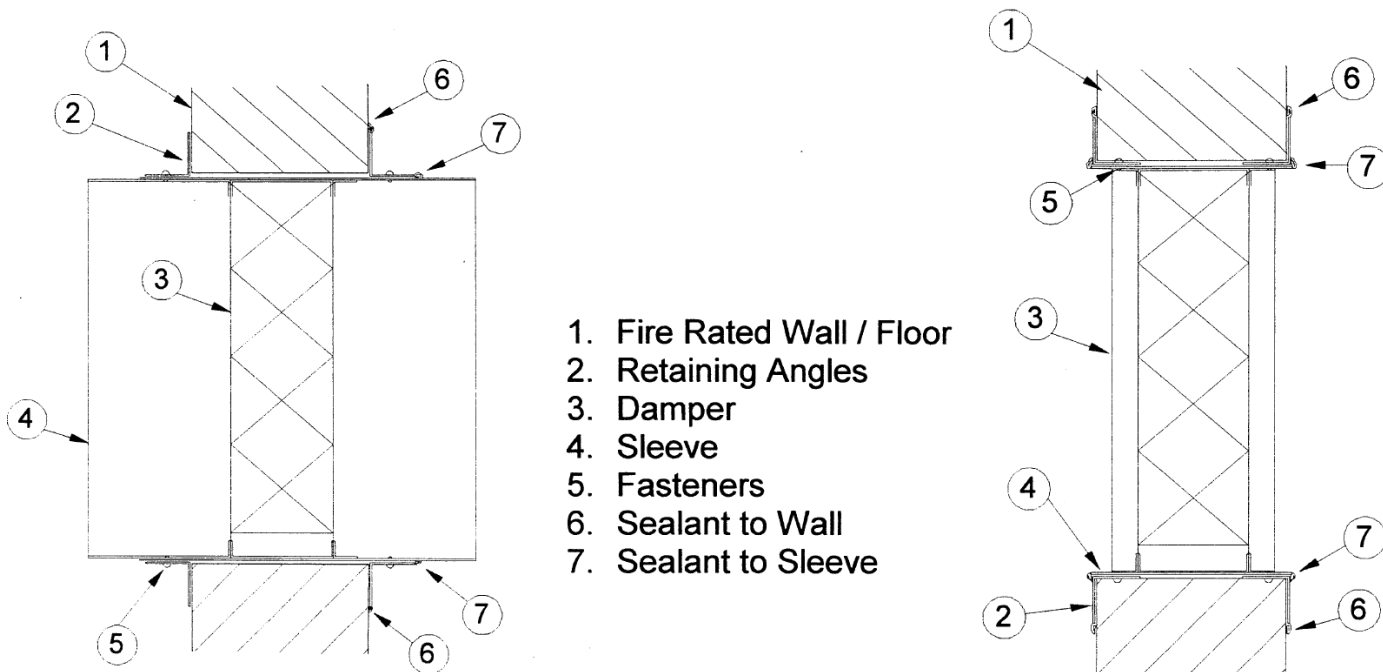

1. Fire Rated Wall / Floor
2. Retaining Angles
3. Damper
4. Sleeve
5. Fasteners
6. Sealant to Wall
7. Sealant to Sleeve

1. Refer to the installation instructions provided on the previous pages for details concerning proper installation of damper.
2. Clean all areas where sealant will be applied. Remove dirt, grease, and moisture from surface to be sealed. Allow to dry thoroughly.
3. Using GE RTV 108, Dow Corning® or Silastic 732 RTV, apply a continuous bead around the outside perimeter of the retaining angle and partition (6). Also apply a continuous bead between the retaining angle and damper sleeve (7). Be sure to seal joints/corners of retaining angles.
4. Be sure not to apply or get sealant within the required expansion gap between the sleeve and fire partition. This gap is required for thermal expansion in the event of fire or extreme heat.
5. After sealant is applied and before set-up, press surface of sealant in place to dispel any air. Do not operate damper until sealant is fully cured and tack-free.

Damper/Field-Sleeve Connection:

1. Per NFPA 90A and SMACNA Duct Construction Standards, the sleeve gauge shall be equal to or heavier than the gauge of the duct when one or more of the following duct connections are used: s-slip, hemmed s-slip, standing s-slip, reinforced standing s-slip, inside slip joint and double s-slip.
2. Damper shall be fastened to sleeve with ½" welds spaced 6" center-to-center. If any duct-damper connections are used other than those above, a separate sleeve shall be fabricated. Maximum thickness for a sleeve shall be 0.138" for coated steel, 0.135" for uncoated steel. For dampers up to 36"W x 24"H, minimum sleeve thickness is 0.56" for coated steel, 0.53" for uncoated steel. For dampers greater than 36"W x 24"H, minimum sleeve thickness is 0.70" for coated steel, 0.67" for uncoated steel. Connection ducts shall not be continuous and terminate at the sleeve or frame.
3. Sleeves shall not extend more than 6" beyond the partition and 16" on opposite side for actuator mounting and/or access doors. Sleeve may extend up to 16" on both side of partition if actuator is installed on one side and access door on opposite side.



Installation Instructions In Conformance To
Underwriters Laboratories Requirements

INSTALLATION INSTRUCTIONS

Remote/Resettable Operator for Fire/Smoke Dampers: Models TTD, STD & BIP:

In conventional HVAC systems, the fan is designed to shut off in case of fire or smoke alarm. Engineering advancements have been developed for smoke removal. In engineered smoke control systems, fans remain on and necessary dampers are opened or closed to safely evacuate smoke from a building.

Model TTD allows a fire fighter to override the primary temperature sensor (165°F or 212°F) or smoke alarm and open a closed damper from a master control panel. Model STD allows dampers to be easily tested and reset at the actual damper location. Both models are reusable thermal links which are reset by simply pushing the reset button on the damper (no fusible link to maintain and replace). Each damper is equipped with an electric actuator as an integral component.

Model TTD (Two Thermal Disk) Application:

Fire/Smoke dampers have had the conventional fusible link replaced with a primary temperature sensor (165°F or 212°F) and secondary sensor (250°F or 350°F). Once the temperature in the ductwork reaches the setting of the primary link or a smoke detector sends a signal, the damper closes. At this point, the damper remains closed until the primary sensor is bypassed at the control panel. Once the primary sensor is bypassed, the damper will open and remain open until the temperature reaches the setting of the secondary sensor. Once that sensor has tripped, it may then only be reset at the damper installation site.

Model STD (Single Thermal Disk) Application:

There are situations in which the damper needs to be periodically checked for operation. In this case, the damper may be checked by heating the sensor above its operating temperature, thus shutting the damper. After 1 minute, the sensor may be manually reset, opening the damper. This allows checking the damper without shutting the entire system down.

Model BIP (Blade Indicator Package) Application:

Micro-switches are controlled through cams on the control shaft to indicate the blade position. The micro-switches are then hooked to lights (open and closed) on the control panel. A fire fighter uses these lights to determine which dampers are closed and which are open. These lights will also help detect the proximity of the fire.

UL 555S approved for Leakage Class I, II, and III

UL 555 approved for 1-1/2

UL approved for crimp and airfoil blade damper models

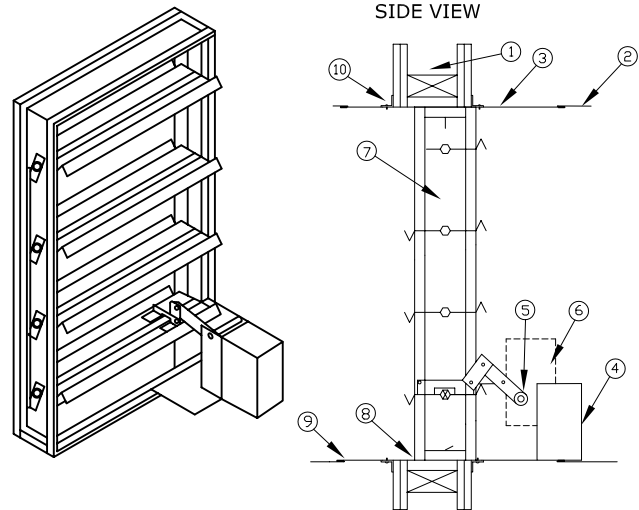
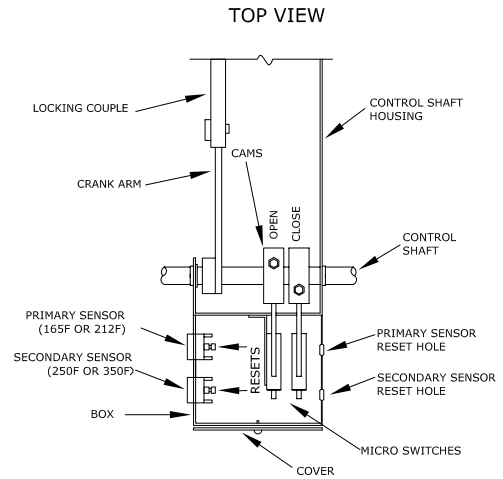

ITEM	DESCRIPTION
1.	Fire Wall
2.	Duct
3.	Sleeve
4.	TTD, STD, and/or BIP
5.	Control Shaft
6.	Operator/ Actuator
7.	Damper Frame
8.	Caulking Material
9.	Slip Joint, Sleeve to Duct
10.	Retaining Angles

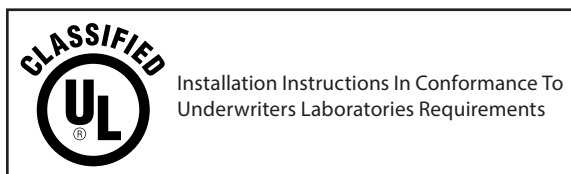

Model B.I.P. Operation

The blade indicator package denotes when the damper is open or closed at the control panel. Wire as shown in Figure 1. When properly wired and damper, in open position, the "open" light on control panel will be lit. If power is disconnected to the actuator, the damper closes. Then the "closed/shut" light on the control panel becomes lit up. Cycle the damper a minimum of three cycles to ensure proper operation.

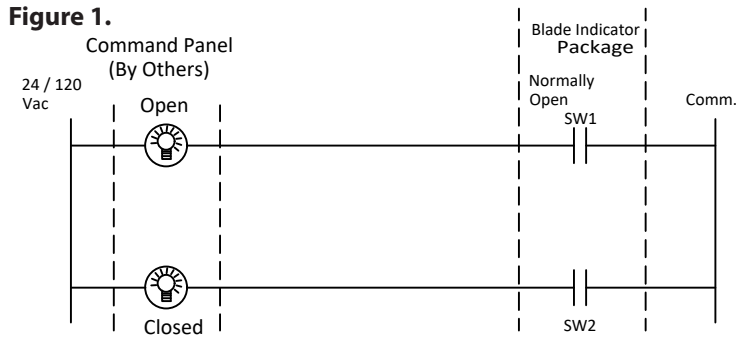

Model S.T.D. Operation

The single thermal disk is used in lieu of a conventional fusible link. Wire an electric operator as shown in Figure 2. Wire a pneumatic actuator as shown in Figure 3. To check operation, open damper. Now heat the sensor disk above its set temperature (usually 165 °F or 212 °F). At this time damper should close. Allow sensor to cool (usually 1 -3 minutes). Using a wood dowel rod (3/16 – 1/4" Dia), place it in the approximate hole on opposite side of the sensor housing (through sleeve). Push it until you hear a click, which resets the thermal sensor. At this time, the damper should reopen. Do not touch face of sensor, because it will destroy calibration of sensor.

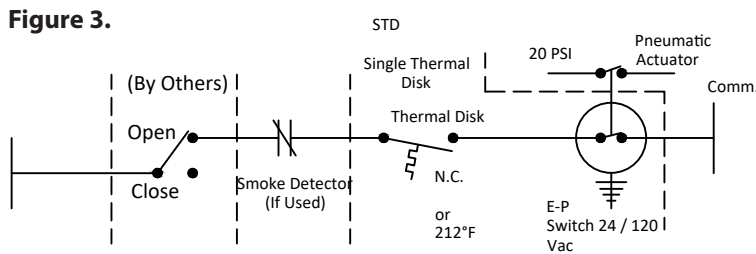
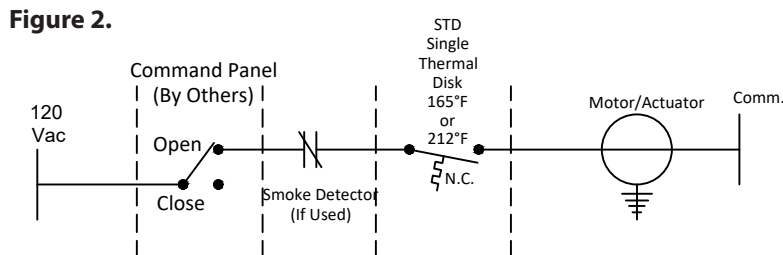

SW1 and SW2 Switch Amp Ratings
 10 Amp, 1/3 HP, 125 or 250 Vac
 0.25 Amp, 250 VDC, 0.5 Amp, 125 V

Model T.T.D. Operation

The two thermal disk system is used in engineer smoke control system. The dampers are wired so that after a smoke detector signal or the primary thermal disk trips and shuts the damper, the damper then can be reopened, until the temperature in the duct reaches the secondary disk temperature. After the temperature passes the secondary temperature setting, the damper will close and cannot be opened. Wire an electronic actuator as shown in Figure 4. Wire a pneumatic actuator as shown in Figure 5. To check operation, open damper. Now heat the lower sensor (closest to the bottom of the damper) above its sensor temperature (usually 165°F or 212°F). The damper should close after you hear a click. Go to the control panel and switch the damper to bypass. At this time, the damper should open up. Now heat the upper sensor (one away from bottom of sleeve) above its operating range (usually 250°F or 350°F). After you hear a click, the damper will close. Allow sensors to cool (usually 1 – 3 minutes). Using a wood dowel rod (3/16 – 1/4" Dia), place it in the approximate holes on the opposite side of the sensor housing box (through sleeve). Push it until you hear a click, which resets the thermal sensor. After resetting both sensors, the damper should open. Do not touch face of sensor because it will destroy calibration of the sensor. Return to the control panel and place switch to normal operating position.

Figure 4.

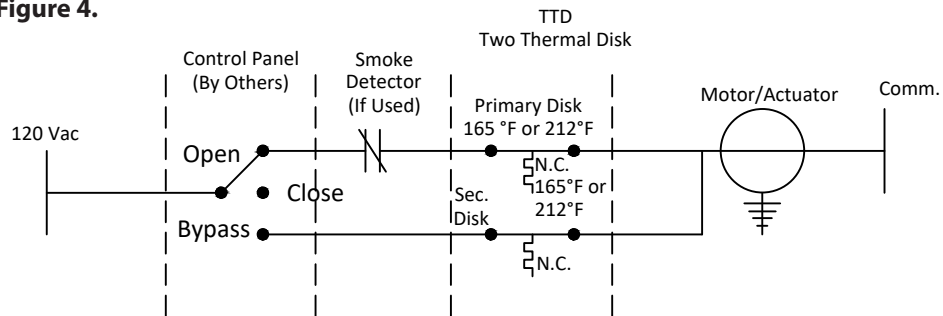
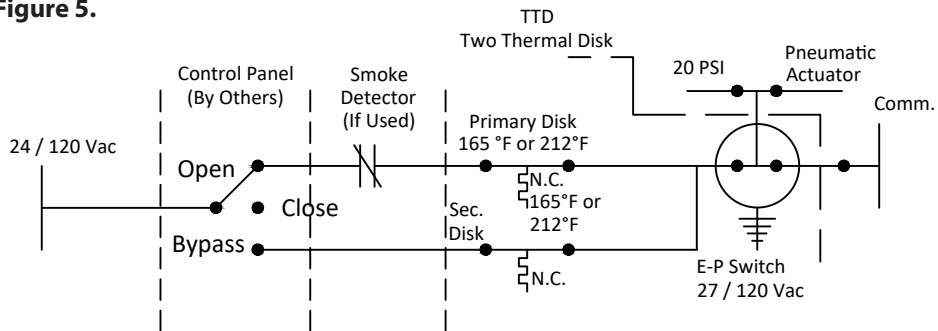

Figure 5.



Model S.T.D. With B.I.P. Operation

Wire electric actuators as shown in Figure 6. Wire pneumatic actuators as shown in Figure 7. Refer to Model B.I.P. Operation and Model S.T.D. Operation for proper operations and checking procedures.

Figure 6.

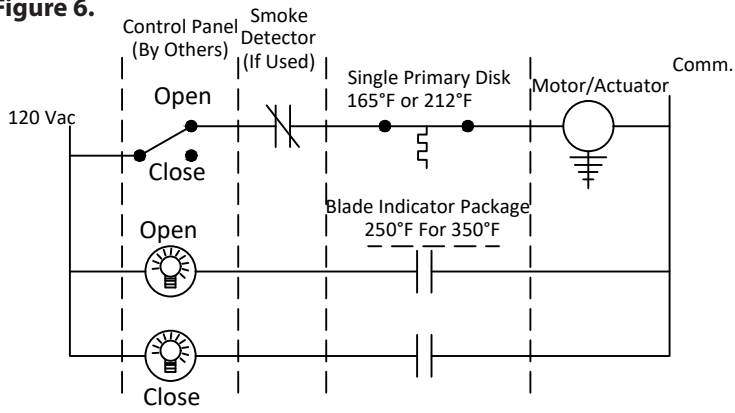
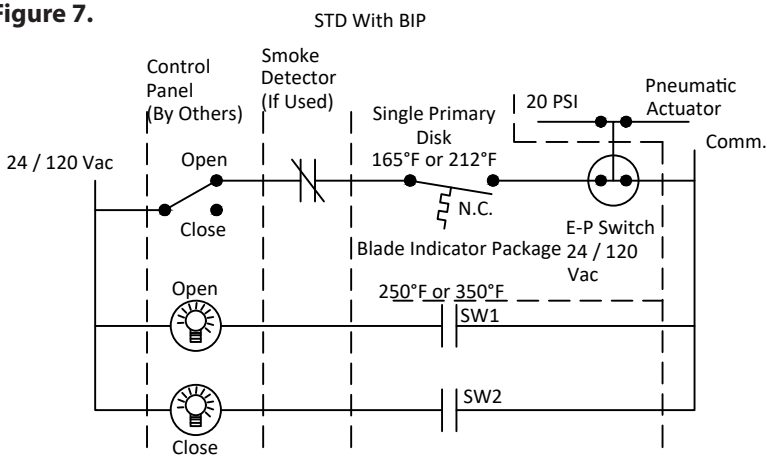

Figure 7.



Model T.T.D. with B.I.P. Operation

Wire Electric Actuators as shown in Figure 8.

Wire Pneumatic Actuators as shown in Figure 9.

Refer to Model B.I.P. Operation and Model T.T.D. Operation for proper operation and checking procedures.

