

# IMPORTANT INSTRUCTIONS



## READ AND SAVE THESE INSTRUCTIONS

No.  
Date

II-123  
July, 2015

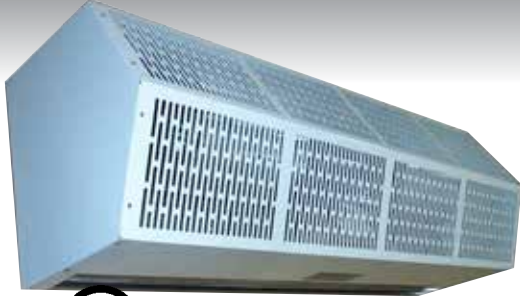

### SANITATION CERTIFIED

High Performance 7  
AIR CURTAIN SERIES SHC07

### COMMERCIAL

High Performance 10  
AIR CURTAIN SERIES CHC10



## Installation & Maintenance Instructions

### TABLE OF CONTENTS

I. UNCRATING.....	2
II. MOUNTING INSTRUCTIONS.....	2
III. WALL MOUNTING.....	3
IV. SUSPENDED MOUNTING.....	3
V. ELECTRICAL CONNECTIONS.....	3
VI. MECHANICAL CONNECTIONS.....	4
VII. OPERATING INSTRUCTIONS.....	4
VIII. MAINTENANCE AND CLEANING.....	5
IX. SERVICE.....	5
X. TROUBLESHOOTING.....	7
XI. WARRANTY.....	8

NSF certification requires maximum mounting height of 7 feet for models SHC07/CHC10 36" & 42"  
EPH certification requires maximum mounting height of 7 feet for all SHC07/CHC10 models

### WARNING: TO REDUCE THE RISK OF FIRE, ELECTRIC SHOCK OR INJURY TO PERSONS, OBSERVE THE FOLLOWING:

- A. Read all instructions before installing or using this air curtain.
- B. Use this unit only in the manner intended by the manufacturer and described in this manual. Any other use not recommended by the manufacturer may cause fire, electric shock, or injury to persons. If you have any questions, contact the manufacturer.
- C. Before servicing or cleaning unit, switch power off at service panel and lock the service disconnecting means to prevent power from being switched on accidentally. When the service disconnecting means cannot be locked, securely fasten a prominent warning device, such as a tag, to the service panel.
- D. Installation work and electrical wiring must be done by qualified person(s) in accordance with all applicable national and local codes having jurisdiction, including fire-rated construction. See page 3, ELECTRICAL CONNECTIONS (NEC Code ANSI/NFPA No. 70).
- E. When cutting or drilling into wall or ceiling, do not damage electrical wiring and other hidden utilities.
- F. To reduce the risk of fire, do not store or use gasoline or other flammable vapors and liquids in the vicinity of the air curtain.
- G. This air curtain is hot when in use. To avoid burns, do not let bare skin touch hot surfaces. Keep combustible materials, such as furniture, pillows, bedding, papers, clothes, etc. and curtains at least 1 inch from the top, back, front, sides and at least 6 feet from the discharge of the air curtain.
- H. Extreme caution is necessary when any air curtain is used by or near children or invalids, and whenever the heater is left operating unattended.
- I. Do not operate any air curtain after it malfunctions. Disconnect power at the service panel and have the air curtain inspected by a reputable electrician before reusing.
- J. To disconnect the air curtain, turn controls to "off", and turn off power to the air curtain circuit at main disconnect panel.
- K. Do not insert or allow foreign objects to enter any ventilation or discharge opening as this may cause an electric shock or fire, or damage the air curtain.
- L. To prevent a possible fire, do not block the air intake or discharge of the air curtain in any manner.
- M. The air curtain has hot and arcing or sparking parts inside. Do not use it in areas where gasoline, paint, or flammable vapors or liquids are used or stored.
- N. This heater may include an audible or visual alarm to warn that parts of the heater are getting excessively hot. If the alarm sounds (or illuminates), immediately turn the heater off and inspect for any objects on or adjacent to the heater that may have blocked the airflow or otherwise caused high temperatures to have occurred. DO NOT OPERATE THE HEATER WITH THE ALARM SOUNDING (OR ILLUMINATING).

## I. UNCRATING

Carefully examine the carton(s) for damage before opening. If the carton is damaged, immediately notify shipping company. If the unit(s) were shipped on wooden skids, remove protective wood and banding straps securing the carton(s) to the skid. Open the carton(s) and remove all protective packaging. Remove the plastic cover housing by lifting vertically. Remove and discard four (4) nuts and washers holding the motor/blower section to the bottom of the carton. Remove motor/blower section from the carton.

**CAUTION: ONLY LIFT THE UNIT BY GRASPING INLET RINGS ON THE BLOWER HOUSING WITHOUT TOUCHING BLOWER WHEELS.**

Immediately verify that the electrical rating nameplate located on the cover matches electrical power supply available. Retain the shipping carton(s) until the unit(s) are installed and properly operating.

**ACCESSORIES:** If the unit(s) were ordered with optional electrical accessories (door switch, control panel, etc.), the accessories may be found in the carton containing the unit or in a separate carton(s) accompanying the unit(s). Check all of the cartons/skids for accessories before discarding.

## II. MOUNTING INSTRUCTIONS (General)

**INDOOR MOUNTING** - Environmental/Insect Dust Control

**OUTDOOR MOUNTING** (Unheated Only) - Insect/Dust Control

The SHC07/CHC10 Air Curtain is designed to be an effective barrier against cold drafts in the winter and hot air in the summer. To achieve optimum protection, the unit should be mounted on the inside of the building, flush to the wall and as close to the top of the door opening as possible. To ensure peak performance keep air stream free of obstructions.

**The Air curtain will not perform properly if negative air pressure exists in the building. Under these conditions, a means for makeup air to the building must be provided so that the air pressure on both sides of the opening is in balance.**

Before mounting the unit, check the supporting structure to verify that it has sufficient load-carrying capacity to support the weight of the unit(s).

MODEL	Net Weight		MODEL	Net Weight
	CHC08 Ambient	CHC08 Electric		SHC07 Ambient
CHC10-1036	50	52	SHC07-1036	50
CHC10-1042	52	55	SHC07-1042	52
CHC10-1048	53	56	SHC07-1048	53
CHC10-1060	54	63	SHC07-2060	70
CHC10-2060	70	96	SHC07-2072	84
CHC10-2072	84	104	SHC07-2084	104
CHC10-2084	104	110	SHC07-2096	106
CHC10-2096	106	112	SHC07-3108	150
CHC10-3096	120	148	SHC07-3120	152
CHC10-2108	107	119		
CHC10-3108	150	156		
CHC10-2120	108	126		
CHC10-3120	152	159		

**TABLE 2 - CHC10 Unit Weight**

**TABLE 1 - SHC07 Unit Weight**

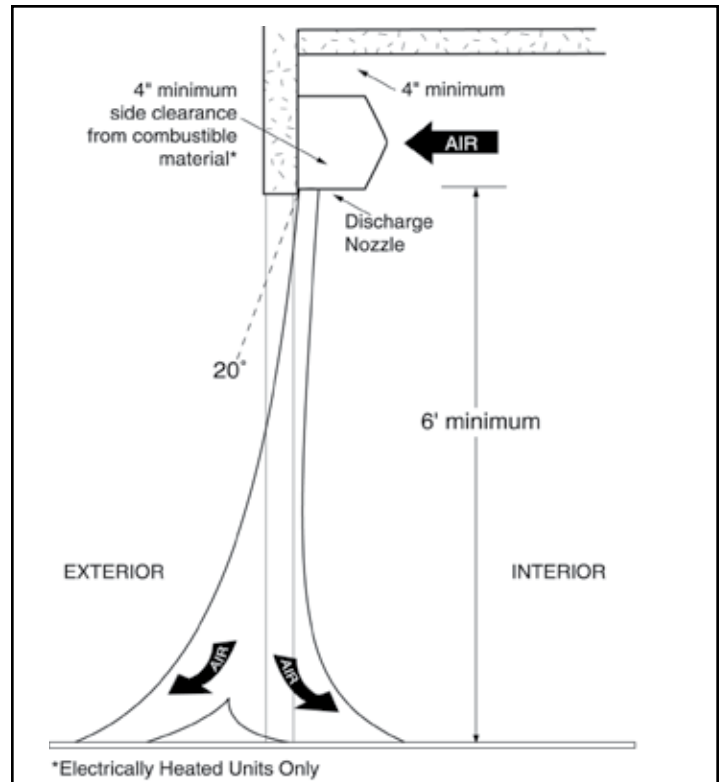

**FIGURE 1 - Air Stream**

The mounting hardware (supplied by others) should be capable of supporting a minimum of three (3) times the weight of the unit.

**See Table 1.**

**NOTE:** The Air curtain is weatherproof, therefore no special covering is required for outdoor mounting.

**IMPORTANT:** A minimum of 4" is recommended above the top of the Air curtain for the installation and removal of the cover housing.

A. When determining the mounting location for the unit(s), make sure that nothing interferes with the curtain of air developed when the discharge vanes are directed from 0° to 20° toward the door opening. If the air stream strikes any obstruction (the top edge of the doorway, a door opening device, etc.), the effectiveness of the unit will be greatly reduced. **See Figure 1.**

B. For optimum performance, the bottom of the unit (discharge nozzle) should be no more than 1" above the top of the door opening with the unit mounted flush to the wall. If the unit must be mounted higher, it must be **spaced out** from the wall  $\frac{3}{8}$ " for every inch the unit is above the door opening. For optimum protection, any void between the Air curtain and the wall should be sealed along the full length of the unit.

**See Figure 2.**

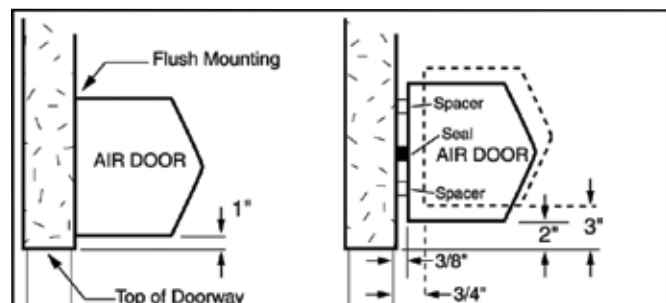

**FIGURE 2**

C. **Electric heated units shall:**

1. Have a minimum clearance of at least 4" between the sides and top of the unit and any combustible material.
2. Have a minimum clearance of at least 6' between the bottom of the unit and the floor.
3. Be installed indoors only.

D. Proceed to either **Section III - WALL MOUNTING**, or **Section IV SUSPENDED MOUNTING**

### III. WALL MOUNTING

- A. Determine the location on the wall above the opening where the air curtain will be mounted. This location should center the unit over the opening and provide suitable mounting support. It is recommended to use at least four locations that correspond to the outer corners of the wall mounting plate. **See FIGURE 3.**

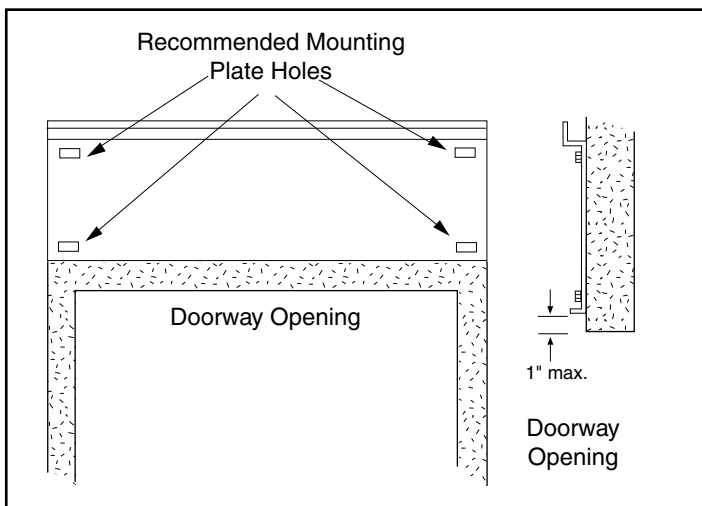

**FIGURE 3 - Positioning of Mounting Plate**

- B. Prepare the wall as necessary for the wall mounting plate anchors (by others).
- C. Drill holes in the wall mounting plate to correspond to the locations on the wall.
- D. Anchor the wall mounting plate over the door opening with the mounting tabs pointing upwards.
- E. Raise the unit over the door (air nozzle facing down) and onto the mounting plate. Tilt the unit upward, matching the holes in the frame with the tabs on the mounting plate.

**See FIGURE 4.**

- F. Lower the unit into place allowing it to rest on the mounting plate. The unit flange should rest above the mounting plate flange.
- G. After the unit is securely seated to the mounting plate, install the locking screws along the bottom flange. **See FIGURE 4.**
- H. Proceed to **Section V-ELECTRICAL CONNECTIONS**

### IV. SUSPENDED MOUNTING (Ceiling Suspension)

- A. When the unit is top mounted, the wall mounting plate is designed to store on the back of unit for future use.

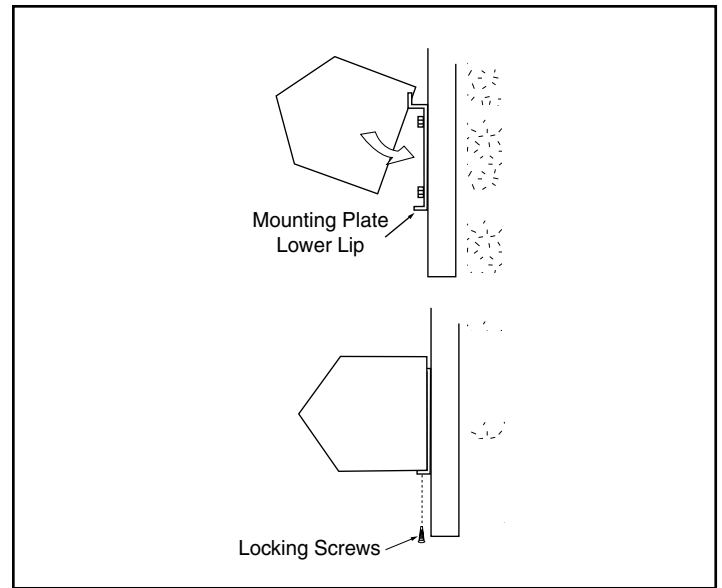

**FIGURE 4 - Attaching Unit to Mounting Plate**

- B. Four (4) factory installed #10-24 threaded inserts are located on the top of the unit for top suspension mounting. Remove screws from inserts. **See FIGURE 5.**

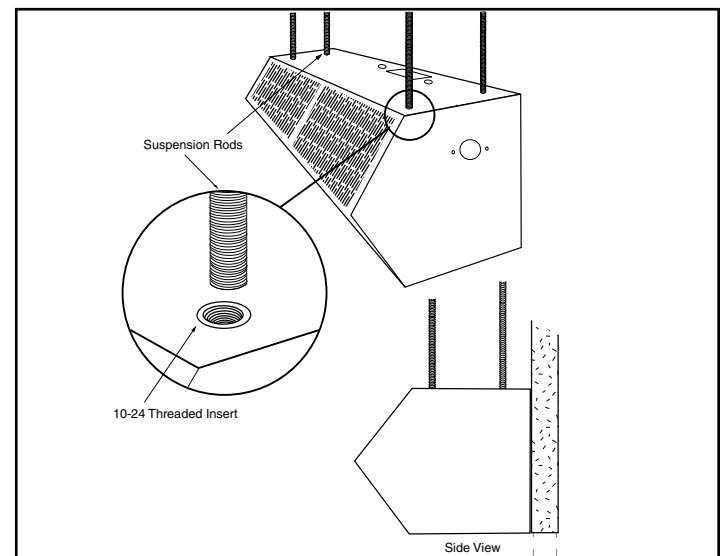

**FIGURE 5 - Suspended Mounting**

- C. Determine the exact mounting location of the air curtain.
- D. The top of the unit is provided with an electrical knockout for power connection. Remove the wiring tray compartment cover. Remove the knockout and attach necessary electrical hardware. Save the wiring diagram found inside of wiring tray.
- E. Attach #10-24 threaded rods, or other suitable hardware to the top mounted threaded inserts.
- F. Proceed to **Section V-ELECTRICAL CONNECTIONS**

## V. ELECTRICAL CONNECTIONS

All electrical wiring and connections **MUST** be performed by qualified personnel in accordance with the National Electrical Code ANSI/NFPA No. 70 (latest edition) or, in Canada, the Canadian Electrical Code, Part 1-C.S.A. Standard C22.1 and local codes and regulations.

- A. Check the electrical rating nameplate on the top of the air curtain for supply voltage and current requirements. A separate line voltage supply with a suitable branch circuit protection device should be run directly from the main electrical panel to the air curtain. A disconnect switch for each branch circuit is a required part of this installation.
- B. All field wiring must be copper with a minimum insulation of 60° C within approved conduit. If any of the wire supplied with the air curtain must be replaced, it must be replaced with copper wiring with a minimum insulation of 90° C.
- C. Remove the wiring tray cover; on air curtains that are comprised of modules, remove the wiring tray cover that is located closest to the electrical rating nameplate (if it has not already been done). **See FIGURE 6.**
- D. The top of the air curtain has two knockouts on each side of the air curtain, allowing for a left hand or right hand power connection. Remove the required knockout if it has not already been done and connect the power supply to the air curtain. Connect all supply and control circuit wires according to the wiring diagram provided.

**NOTE: For Electrically Heated air curtain(s) provided with the optional remote thermostat: mount and wire the thermostat according to instructions and wiring diagram.**

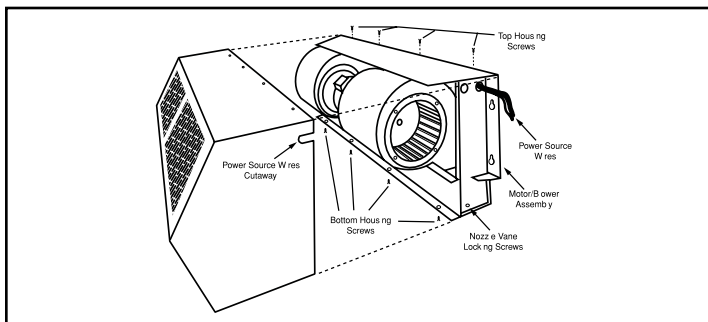

**FIGURE 6 - Removing Cover**

## VI. MECHANICAL CONNECTIONS

### A. ELECTRICALLY HEATED MODELS

The heater circuit may be controlled by a remote thermostat, or manually through a remote mounted three position - fan only/off/fan with heat switch. Overheating protection is provided by auto reset thermal cutouts built into the blower assembly (see wiring diagram). Proceed to **Section VII - OPERATING INSTRUCTIONS.**

## VII. OPERATING INSTRUCTIONS

### A. GENERAL OPERATION

Air curtain operation may be divided into four areas: control package, fan activation, fan speed selection, and heat activation. Depending on the type of controls ordered one or more of the following may be applicable. The air curtain must be properly installed before it is used.

1. Control packages control the unit's sequence of operation. Unit modes/control packages are built into the unit and may not be changed in the field. Refer to your wiring diagram for specifics about activation connections and sequence of operation.
  - a. Basic Control Package – The unit is activated by a door or selector switch. Either switch may be line voltage or low voltage (24V).
  - b. Deluxe Control Package – The unit is activated by a door or selector switch, but has a factory installed time delay allowing the unit to keep running for a period of time after the door closes.
  - c. Comfort Plus Control Package – Available only on heated units, the unit is activated by a door or selector switch AND a thermostat to provide supplemental heating. NOTE: Not available with 575V motors.
2. Unheated units will have the fans activated by a door or selector switch or sensor. The unit may be single speed and require no fan speed selector (On/Off), or may have multiple fan speeds which require either a unit or remote mounted switch (Off, High, Med, Low).
3. Heated units will have fans activated by a door or selector switch or sensor, but may also be activated by the thermostat in Comfort Plus Mode. The unit may be single speed and controlled by either a unit or remote mounted switch (Fan, Off, Heat), or may have multiple fan speeds which can be set by either a unit or remote mounted switch (Low, Med, High, Off, Low heat, Med Heat, High Heat).
4. Heat activation is controlled by either a unit or remote mounted thermostat, and a unit or remote mounted switch.

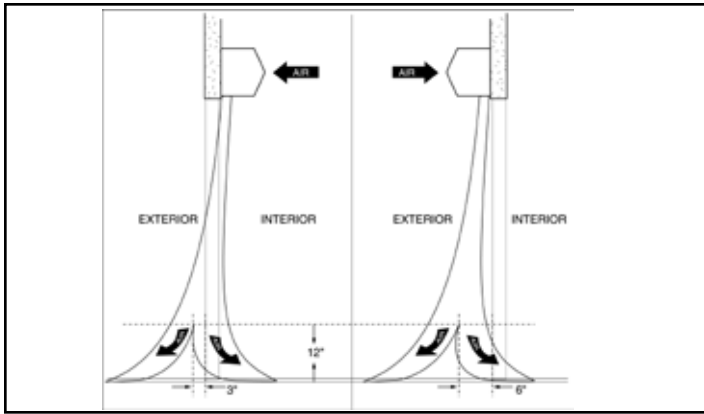

**FIGURE 7 - Air Flow Adjustment**

**B. AIR STREAM ADJUSTMENT**

1. With the air curtain operating and the door in its full open position, check to see that nothing is obstructing the airflow at the discharge nozzle vanes.
2. Find the air stream split location. Hold a handkerchief by its corners, approximately 12" above the floor. Gently move the handkerchief back and forth in the doorway. Make sure the air is being directed to both the inside and the outside. **See Figure 7.** The split location is indicated where the handkerchief is vertical with minimal or no fluttering.
3. The split location should be approximately 3" outside the doorway. If necessary adjust the discharge nozzle vanes by de-energizing the unit, loosening the nozzle vane locking screws and adjusting vanes.

**VIII. MAINTENANCE AND CLEANING**

**CAUTION: ELECTRIC SHOCK HAZARD**

**Disconnect power whenever servicing unit. More than one disconnect may be required to de-energize unit.**

Keep your Air curtain operating at peak efficiency by cleaning the blower wheels, motor(s) and intake grille. Buildup of dust on the blower wheels can cause vibration, noise and excessive wear on the motor bearings. The frequency of cleaning will depend on the environment where the unit is operating.

Dirty, dusty or greasy environments could require a cleaning schedule of once every two months. Otherwise, the unit(s) should be scheduled for cleaning a minimum of once every (6) months. To access the interior of the unit:

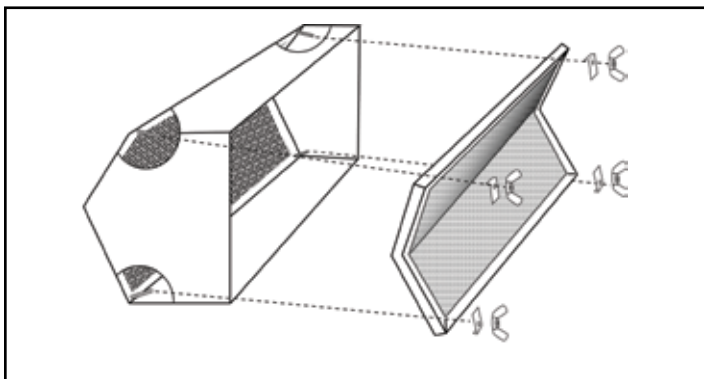

**FIGURE 8 - Filter Replacement**

- A. Disconnect and lockout power to the unit. Remove unit cover housing by removing screws from the top and bottom of unit. Slide cover housing away from blower assembly to remove. If the unit has a filter, it should be removed and cleaned at this time. The filter is located in the cover housing and held in place by wing nuts and clips. **See Figure 8.**
- B. Vacuum and scrape (if necessary) to remove the buildup of dirt and debris from the interior of the Air curtain. The motor(s) are permanently lubricated and require no additional lubrication. Reinstall the cover housing.
- C. Switch the power on after cleaning.

**CAUTION: STAND CLEAR OF THE UNIT OR WEAR SAFETY GOGGLES AS LOOSE DEBRIS MAY BE PRESENT AND MAY EXIT THE NOZZLE.**

**IX. SERVICE**

**CAUTION: ELECTRIC SHOCK HAZARD Disconnect power whenever servicing unit. More than one disconnect may be required to de-energize unit.**

*Any service performed on the SHC07/CHC10 Series Air curtain **MUST** be done by qualified personnel.*

Berner Air curtains require very little servicing. All parts are easily accessible for periodic inspection and maintenance. Units should be cleaned at least twice a year. Your particular application (the amount of dirt and dust in the air) and location of the unit(s) will determine how often your unit(s) will need to be cleaned and serviced. All motors have permanently lubricated, sealed, sleeve bearings and require no maintenance.

**A. Fan Wheel Removal - Ambient and Electric Heated**

1. Disconnect and lockout power to the unit. Remove unit cover housing by removing screws from the top and bottom of unit. Slide cover housing away from blower assembly to remove.
2. If unit is equipped with inlet rings and/or tri-arm bearings, remove outside ring and/or bearing using a blade screw driver or 1/4" nut driver. If unit does not have inlet rings proceed to next step.
3. Loosen (**do not remove**) 5/32" Allen head set screw from hub of fan wheel. Note: a T-handle Allen wrench may be inserted through hole in fan housing and fan blade with semi-circle notch.
4. Carefully slide fan wheel out of fan housing.
5. Reinstall fan wheel and align set screw with flat on motor shaft.
6. Slowly tighten set screw while gently rocking fan wheel back and forth to settle set screw perpendicular to motor shaft flat.
7. Reinstall inlet ring and/or bearing if necessary.
8. Reinstall unit cover housing and switch on power.

**B. Motor Removal - Ambient and Electric Heated**

1. Disconnect and lockout power to the unit. Remove unit cover housing by removing screws from the top and bottom of unit. Slide cover housing away from blower assembly to remove. For electric heated units, mark connections and disconnect four spade wire terminals from electric heater(s).
2. Unplug wiring harness from motor.



3. Loosen (**do not remove**)  $\frac{5}{32}$ " Allen head set screw from hub of each fan wheel attached to motor. Note: a T-handle Allen wrench may be inserted through hole in fan housing and fan blade with semi-circle notch. If unit is equipped with an extended shaft and coupling for a three fan, one motor construction, this fan assembly must be disconnected from motor shaft. Loosen  $\frac{5}{32}$ " set screw on third fan wheel hub. Loosen set screw on motor shaft side of coupling (silver coupling -  $\frac{5}{32}$ " Allen wrench, black coupling -  $\frac{9}{64}$ " Allen wrench). Slide coupling and shaft off motor shaft by gently pushing it through third fan hub.
  4. Remove four phillips head screws from each fan housing that has a fan attached to motor.
  5. Remove each fan and housing assembly from motor shaft by sliding away from motor. After fan wheel is off motor shaft, remove assembly by rotating it away from the blower assembly.
  6. While supporting motor, loosen and remove two clips that hold motor with a straight blade screw driver or  $\frac{5}{16}$ " nut driver.
  7. Remove motor.
  8. Install motor in reverse order of removal.
2. Loosen (**do not remove**)  $\frac{5}{32}$ " Allen head set screw from hub of fan wheel. Note: a T-handle Allen wrench may be inserted through hole in fan housing and fan blade with semi-circle notch.
  3. Remove four phillips head screws from fan housing.
  4. Remove fan and housing from motor shaft by sliding assembly away from motor. After fan wheel is off of motor shaft, remove assembly by rotating it away from blower assembly.
  5. Remove electric heater element from fan housing by removing three screws with  $\frac{1}{4}$ " nut driver.
  6. Reinstall in reverse order of removal.

### C. Fan Wheel and Housing Removal - Ambient and Electric Heated

1. Disconnect and lockout power to the unit. Remove unit cover housing by removing screws from the top and bottom of unit. Slide cover housing away from blower assembly to remove. For electric heated units, mark connections and disconnect four spade wire terminals from electric heaters.
2. Loosen (**do not remove**)  $\frac{5}{32}$ " Allen head set screw from hub of fan wheel. Note: a T-handle Allen wrench may be inserted through hole in fan housing and fan blade with semi-circle notch.
3. Remove four phillips head screws from fan housing.
4. Remove fan and housing from motor shaft by sliding assembly away from motor. After fan wheel is off of motor shaft, remove assembly by rotating it away from blower assembly.
5. Reinstall in reverse order of removal.

### D. Filter Replacement

1. Disconnect and lockout power to the unit. Remove unit cover housing by removing screws from the top and bottom of unit. Slide cover housing away from blower assembly to remove.
2. Filter is located in cover housing. Remove wing nuts and clips that hold filter. **See Figure 8.**
3. Remove and replace filter. Note: clean aluminum filters with water and a mild detergent, rinse thoroughly.
4. Reinstall in reverse order of removal.  
Note: do not force or over tighten wing nuts as they will thread through the outside of cover housing.

### E. Electric Heater Removal - Electric Heated

1. Disconnect and lockout power to the unit. Remove unit cover housing by removing screws from the top and bottom of unit. Slide cover housing away from blower assembly to remove. Mark connections and disconnect four spade wire terminals from electric heater(s).

## X. TROUBLESHOOTING

SYMPTOMS	CAUSE	REMEDY
<b>NO AIR</b>	<ul style="list-style-type: none"> <li>• Electrical Power supply line open (no power)</li> <li>• Fuse blown/circuit breaker tripped</li> <li>• Motor overload tripped</li> <li>• Failed switch</li> </ul>	<ul style="list-style-type: none"> <li>• Check power source, check method of control in ON position</li> <li>• Replace fuse(s)/reset breaker</li> <li>• Internally protected motor - should reset automatically after cool-down, if not replace motor.</li> <li>• Replace switch</li> </ul>
	<b>MOTOR RUNNING/FANS ARE NOT ROTATING</b>	
	<ul style="list-style-type: none"> <li>• Broken or fan hub</li> <li>• Shaft rotating inside fan</li> <li>• Broken/Loose coupling</li> </ul>	<ul style="list-style-type: none"> <li>• Replace fan</li> <li>• Tighten set screws/tighten fan on shaft</li> <li>• Replace/Tighten coupling</li> </ul>
	<b>ELECTRICAL CONTROLS NOT FUNCTIONING WHEN DOOR IS OPEN</b>	
	<ul style="list-style-type: none"> <li>• Selector switch is in off position</li> <li>• Door limit switch not operating</li> </ul>	<ul style="list-style-type: none"> <li>• Turn switch to "ON" position</li> <li>• Repair or replace limit switch</li> </ul>
<b>MINIMUM</b>	<ul style="list-style-type: none"> <li>• Air directional discharge vanes misadjusted</li> <li>• Inadequate intake clearance</li> <li>• Blower motor operates below speed</li> <li>• Fan rubbing against housing</li> <li>• Fan wheels clogged with dirt</li> </ul>	<ul style="list-style-type: none"> <li>• Adjust vanes to proper position, see instructions</li> <li>• Move air curtain or remove obstruction Provide adequate space for air curtain</li> <li>• Improve voltage</li> <li>• Free fan from housing</li> <li>• Clean and vacuum fan wheels</li> </ul>
<b>AIR IS NOT HITTING FLOOR</b>	<ul style="list-style-type: none"> <li>• Air stream too weak</li> <li>• Air stream hits obstruction</li> <li>• Negative pressure</li> </ul>	<ul style="list-style-type: none"> <li>• Adjust nozzle to proper position, adjust motor speed; see installation instructions</li> <li>• Remove obstruction or reposition air curtain (move out <math>\frac{3}{8}</math>" for every 1" up from the door)</li> <li>• Relieve negative pressure by providing make-up air</li> </ul>
<b>UNEVEN AIR</b>	<ul style="list-style-type: none"> <li>• Shaft rotating inside fan</li> <li>• One motor not operating</li> </ul>	<ul style="list-style-type: none"> <li>• Tighten set screws/Replace fan</li> <li>• Repair or replace motor/Check electrical connections</li> </ul>
<b>EXCESSIVE AIR MOVEMENT AT DOORWAY</b>	<ul style="list-style-type: none"> <li>• Nozzle not angled out far enough</li> <li>• Air movement too cold</li> <li>• Pushing air outside building</li> </ul> <p>SEE AIR IS NOT HITTING FLOOR SYMPTOMS</p>	<ul style="list-style-type: none"> <li>• Adjust nozzle angle to outside</li> <li>• Add auxiliary heat to overcome wind chill</li> <li>• Adjust discharge angle back into building</li> </ul>
<b>ELECTRICALLY HEATED MODELS</b>		
<b>NO HEAT</b>	<ul style="list-style-type: none"> <li>• Switch turned to "OFF" position</li> <li>• Thermostat not set properly</li> <li>• Coils burned out due to lack of air</li> <li>• Automatic reset thermal cutout failed in open position</li> <li>• Manual reset thermal cutout tripped</li> <li>• Defective switch</li> </ul>	<ul style="list-style-type: none"> <li>• Turn switch on</li> <li>• Change thermostat setting</li> <li>• Correct airflow problem; replace coils</li> <li>• Replace automatic thermal cutout</li> <li>• Reset manual thermal cutout</li> <li>• Replace switch</li> </ul>
<b>NOT ENOUGH HEAT</b>	<ul style="list-style-type: none"> <li>• Thermostat in wrong location - thermostat too close to discharge</li> <li>• Improper voltage</li> <li>• Thermostat not set properly</li> </ul>	<ul style="list-style-type: none"> <li>• Move thermostat away from air stream</li> <li>• Supply proper voltage</li> <li>• Change temperature setting</li> </ul>
<b>TOO MUCH HEAT</b>	<ul style="list-style-type: none"> <li>• Thermostat in wrong location</li> <li>• Thermostat not set properly</li> <li>• Insufficient air over coil</li> <li>• Improper voltage</li> </ul>	<ul style="list-style-type: none"> <li>• Move thermostat closer to air stream</li> <li>• Change temperature setting</li> <li>• Remove restriction on intake</li> <li>• Supply proper voltage</li> </ul>

# XI. WARRANTY

Berner International ("The Company") warrants all new equipment to be free of defects in workmanship and material for a period of five years (5 years) on unheated models and two years (2 years) on heated models from the original date of shipment, provided the equipment has been properly cared for, installed and operated in accordance with the limits specified on the nameplate and The Company's instructions.

The Company will correct by repair or replacement, at its option and expense, any proven defects in said apparatus, subject to the above conditions, provided that immediate written notice of such defects is given to The Company. The warranty does not include any labor incurred for the removal or installation of defective part(s). The Company reserves the right to inspect, or have inspected by a qualified representative, any apparatus at the place of installation before authorizing repair or replacement. Repair or replacement will be made F.O.B. factory with any applicable transportation charges to be borne by the customer. Merchandise not of The Company's manufacture supplied in piece, or in component assemblies, is not covered by the above warranty, but The Company will give the customer the benefit of any adjustment as made with the Manufacturer.

This warranty is void if the apparatus has been tampered with in any way or shows evidence of misuse.

The Company will not assume any expense or liability for repairs made outside its factory without proper written consent from its service manager, nor for any transportation charges on apparatus returned to the factory without written authorization by The Company.

Nothing in the above warranty provisions, however, shall impose any liability or obligation of any type, nature or description upon Berner International if Berner has not received payment in full for the apparatus in question.

**THERE ARE NO WARRANTIES WHICH EXTEND BEYOND THE DESCRIPTION ON THE FACE HERE OF INCLUDING THE IMPLIED WARRANTY OF MERCHANTABILITY AND FITNESS FOR A PARTICULAR PURPOSE.**

## LIMITATION OF DAMAGES

**Notwithstanding anything to the contrary above, customer's exclusive remedy for any and all losses or damages resulting from the sale of The Company's equipment under this agreement, including but not limited to, any allegations of breach of warranty, breach of contract, negligence or strict liability, shall be limited, at The Company's option, to either the return of the purchase price or the replacement of the particular equipment for which a claim is made and proved. In no event shall The Company be liable for any special, consequential, incidental or indirect losses or damages from the sale of The Company's equipment under this agreement.**

SERIAL NUMBER	MODEL NUMBER	DATE PURCHASED
---------------	--------------	----------------



**BERNER INTERNATIONAL CORPORATION**  
New Castle, Pennsylvania

**724-658-3551 • 1-800-245-4455 • [www.berner.com](http://www.berner.com) • [airdoors@berner.com](mailto:airdoors@berner.com)**

*Berner reserves the right to alter specifications without prior notice.*