



TT PRO

INLINE MIXED FLOW FANS

PRODUCT SPECIFICATIONS

TECHNICAL DATA

Please see performance table for Energy Star Rated Models



DESCRIPTION

Turbo Tube PRO series is the new ideal engineering solution for premises where powerful, yet quiet airflow is required. The unique motor, powerful mixed flow impeller and special aerodynamic casing combination enables the Turbo Tube PRO fans to deliver superb airflow performance even at higher static pressures typically found in extensive ventilation systems.

The Removable Body, including motor, impeller and junction box, is the Ultimate Solution for Easy Installation & cleaning.

Turbo Tube PRO fans are compatible with 4", 5", 6" diameter ducts.

Five year warranty.

CASING

The fan's casing is made of high quality, UV resistant plastic (flame rating – 5VA). It is equipped with a mounting plate to attach the fan to the wall or ceiling.

MOTOR

Motors are supplied with automatic reset thermal protection and are equipped with ball bearings

for longer service life (40,000 hrs).

Suitable for air stream temperature up to 140 °F.

SUITABLE FOR:

Kitchen / pools / stores / bars / restaurants / offices / public institutions / manufacturies etc

DIMENSIONS

Model	Measurements [in.]					lbs
	ØD	ØD1	B	H	L	
TT PRO 100	3 3/4"	5 1/2"	6 9/16"	7 1/2"	9 11/16"	3.1
TT PRO 125	4 13/16"	5 1/2"	6 9/16"	7 1/2"	9 11/16"	3.1
TT PRO 150	5 3/4"	7 11/16"	8 3/4"	9 13/16"	11 5/8"	6.6

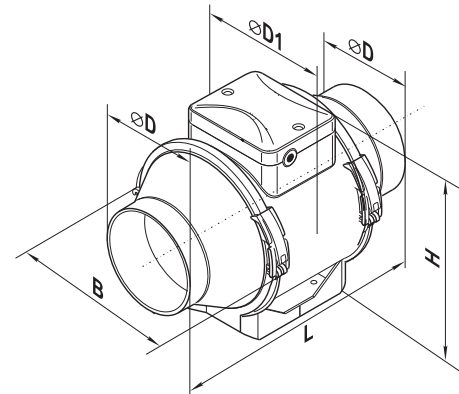

Tel: 888-640-0925
513-348-3853
Fax: 513-268-4597

Sales@ventsus.com
VentsUS.com
11013 Kenwood Road,
Cincinnati, Ohio 45242



2013-03



TT PRO

INLINE MIXED FLOW FANS

PRODUCT SPECIFICATIONS

TECHNICAL DATA

Please see performance table for Energy Star Rated Models

PERFORMANCE

Model	EnergyStar certified	Speed	* RPM	Duct Dia	* Watts	* Amps	CFM vs. Static Pressure (Ps) in WG										Max Ps	Volts/Hz	
							0"	0.1"	0.2"	0.3"	0.4"	0.5"	0.6"	0.7"	0.8"	0.9"			1.0"
TT PRO 100	+	high	2927	4"	48	0.4	210	198	184	164	135	107	79	59	44	26	2	0.78	120/60
		low	2414		38	0.32	144	131	121	106	91	70	51	33	14	2	-	0.61	120/60
TT PRO 125	+	high	3003	5"	62	0.53	286	269	250	229	209	154	99	63	31	-	-	0.70	120/60
		low	2570		48	0.42	221	208	192	173	146	106	73	44	9	-	-	0.48	120/60
TT PRO 150	+	high	2981	6"	81	0.69	378	366	355	342	328	313	298	281	259	233	127	1.22	120/60
		low	2432		75	0.64	313	296	278	258	240	219	198	164	121	82	54	0.93	120/60

* The parameters RPM, Watts are indicated at 0.2 in. WG static pressure.

MODEL	QUANTITY	COMMENTS	PROJECT
			location:
			architect:
			engineer:
			contractor:
			submitted by:

Tel: 888-640-0925
513-348-3853
Fax: 513-268-4597

Sales@ventsus.com
VentsUS.com
11013 Kenwood Road,
Cincinnati, Ohio 45242



2013-03