



Aire Technologies, Inc.
a DMI company

Aire Technologies, Inc.
1502 Industrial Drive
E. Monongahela, PA 15063

phone: 866.421.AIRE
fax 724.310.1262

www.airetechnologies.com

submittal

Job _____
 Location _____
 Submitted to _____
 Submittal Prepared by _____
 Approve Date _____
 Date _____

Fire Damper Series 65 Type B

UL Classified - 1½ Hour Rating, Static
For use in installations rated less than 3 hours

Thinline Profile (2") 22 Ga.
1 piece rollformed frame

Type B Damper
Blades out of air-stream

Available for vertical and horizontal installations

Standard fusible link - 165°F
(or w/optional 212°F)

Available in stainless steel

Available in single-section sizes from
Vertical - 4" x 3" to 48" x 44"
Horizontal - 4" x 3" to 41" x 36"

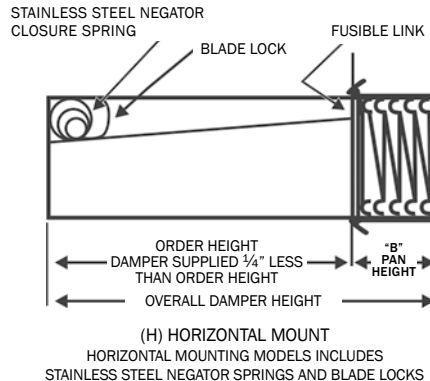
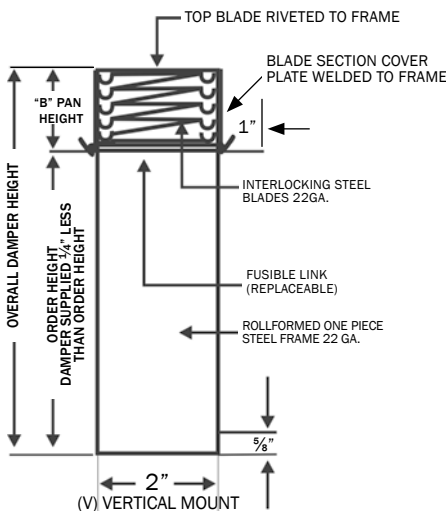
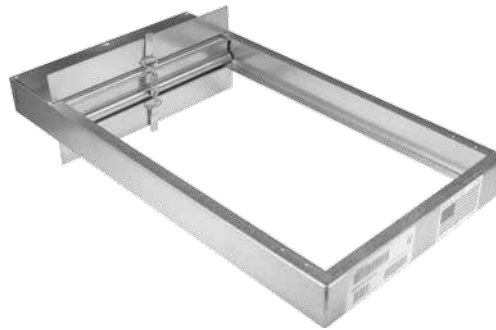

This product meets the requirements for fire dampers established by:

UL Standards 555
NFPA Standard 90A
ICC Building Codes

Qty.	Mount		Damper Size		Fusible Link Temp (165° F) std.	Factory Sleeve Option			
	(V) vertical (H) horizontal	W	H	Dimensions		Gauge	Material		
				L				K	

Part Number Format

6 5 B H 0 2 4 0 1 8 G

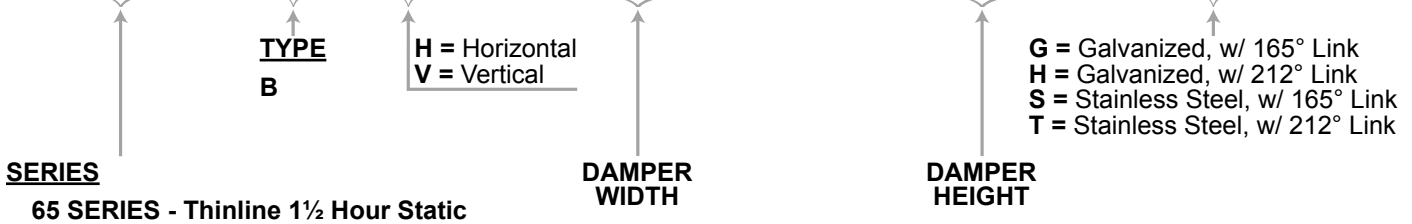

submittal



AireTechnologies, Inc.
a DMI company

AireTechnologies, Inc.
1502 Industrial Drive
E. Monongahela, PA 15063

phone: 866.421.AIRE
fax 724.310.1262

www.airetechnologies.com